

**BG - BH**



***MOTORI ORBITALI***

**HYDRAULIC MOTOR SERIES**

## CARATTERISTICHE DEL MOTORE MOTOR FEATURES

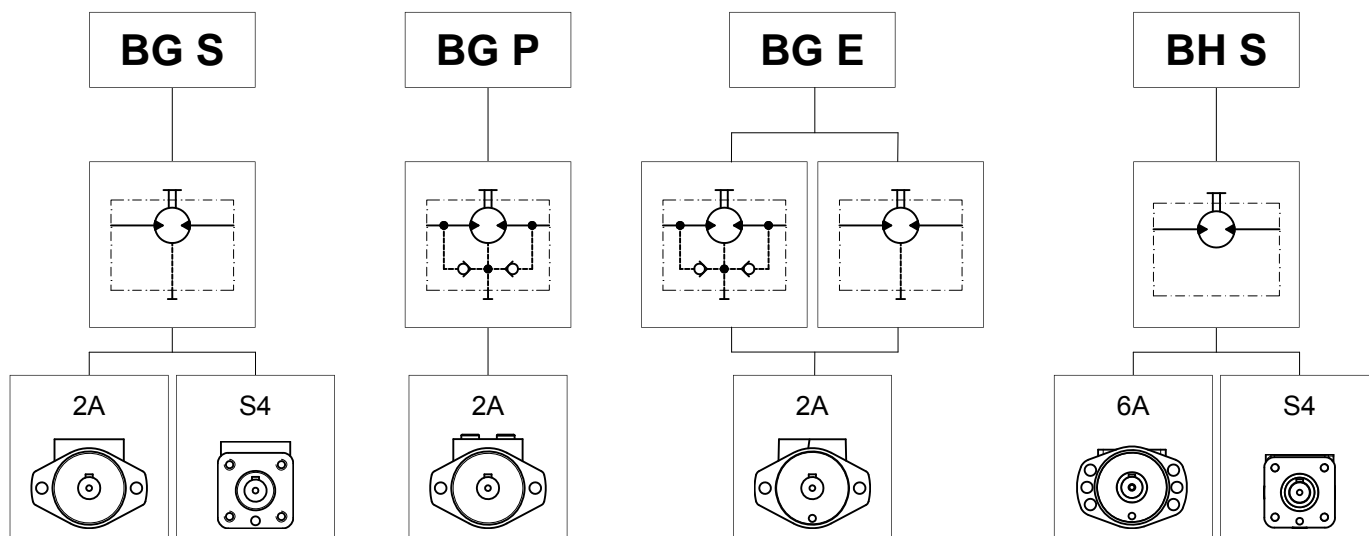

Una ampia gamma di valvole flangiabili, è disponibile su richiesta.  
A wide range of flangeable valves are available on request.

Foro di drenaggio posteriore per un facile collegamento.  
Rear drain port for easier connection.

Flangia a 2 e 4 fori.  
2 bolts and 4 bolts mounting flange option.

Albero cilindrico  $\varnothing 25$  mm e  $\varnothing 25.4$  mm oppure scanalato  $\varnothing 25$  mm.  
0.97 in straight, 1 in straight, 0.97 in splined option.

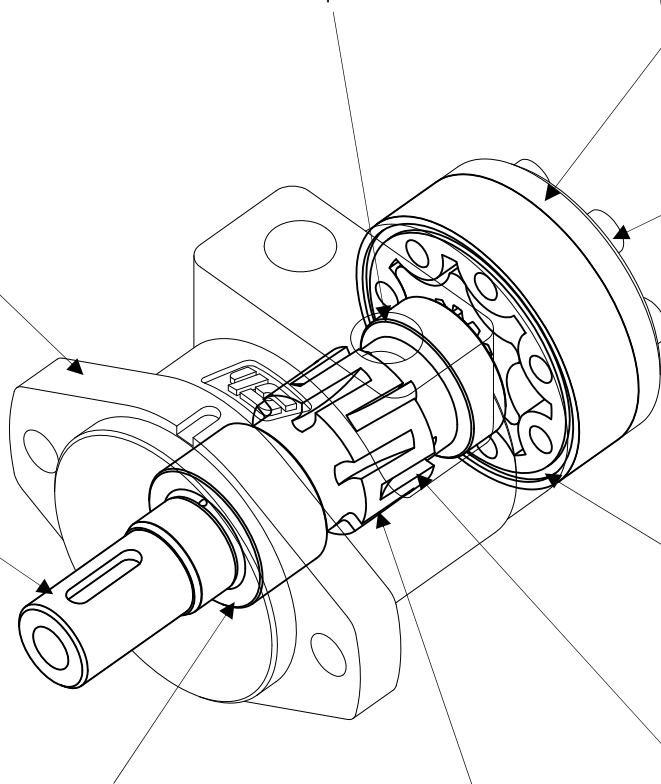

7 viti coperchio posteriore in acciaio ad alta resistenza per sopportare gli sforzi causati dall'alta pressione.  
7 rear cover bolts made of high tensile steel to resist the stress caused by high pressure.

Profilo del gerotor del tipo ad alto rendimento per elevate prestazioni e durata.  
High efficiency profile gerotor set.

Parapolvere per proteggere la guarnizione dell'albero dalle impurità.  
Dust seal to protect the seal from dust.

Valvola di distribuzione integrata nell'albero di distribuzione. Tolleranze molto ridotte assicurano un basso drenaggio.  
Spool valve integral to the output shaft featuring optimized clearance geometry and so minimizing the oil slippage.

Il profilo delle cave assicura un azionamento morbido e silenzioso anche alle velocità più basse.  
Optimized grooves profile to ensure smooth and quiet running even at very low speed.

# CODICI DI ORDINAZIONE ORDERING CODES

Le seguenti lettere o numeri del codice, sono state sviluppate per identificare tutte le configurazioni possibili dei motori BG. Usare il seguente modulo per identificare le caratteristiche desiderate. **Tutte le lettere o numeri del codice devono comparire in fase d'ordine.** Si consiglia di leggere attentamente il catalogo prima di iniziare la compilazione del codice di ordinazione.

The following alphanumeric digits system has been developed to identify all of the configuration options for the BG motors. Use the model code below to specify the desired features. **All alphanumeric digits system of the code must be present when ordering.** We recommend to carefully read the catalogue before filling the ordering code.

## CODICE PRODOTTO / MODEL CODE

1	2	3	4	5	6	7	8	8A	9	10

### 1 - SERIE / SERIES

BG	Motore orbitale Orbital motor
----	----------------------------------

### 2 - VERSIONI / VERSIONS

S	Versione S S Version	STANDARD
E	Versione E E Version	
P	Versione P P Version	

### 3 - CILINDRATA / DISPLACEMENT

050	49 cm <sup>3</sup> /giro [2.99 in <sup>3</sup> /rev]
080	73 cm <sup>3</sup> /giro [4.45 in <sup>3</sup> /rev]
100	101 cm <sup>3</sup> /giro [6.16 in <sup>3</sup> /rev]
130	128 cm <sup>3</sup> /giro [7.8 in <sup>3</sup> /rev]
160	168 cm <sup>3</sup> /giro [10.24 in <sup>3</sup> /rev]
200	195 cm <sup>3</sup> /giro [11.98 in <sup>3</sup> /rev]
250	244 cm <sup>3</sup> /giro [14.88 in <sup>3</sup> /rev]
315	292 cm <sup>3</sup> /giro [17.81 in <sup>3</sup> /rev]
400	390 cm <sup>3</sup> /giro [23.79 in <sup>3</sup> /rev]

### 4 - FLANGIA / MOUNTING FLANGE

		VERSIONI / VERSIONS		
		S	E	P
2A	Ovale 2 Fori Oval 2 Bolts	STANDARD	•	•
S4	4 fori 3/8 16 UNC - Ø44,45mm 4 Bolt 3/8 16 UNC - Ø1.75 in		/	/

• Disponibile - Available / Non Disponibile - Not Available

### 5 - ATTACCHI / MAIN PORTS

		VERSIONI / VERSIONS		
		S	E	P
M08	Attacchi 1/2 G BSPP (40x8) 1/2 G BSPP (40x8) Main Ports	STANDARD	/	/
F08	Attacchi Frontali 1/2 G BSPP 1/2 G BSPP (End Main Ports)	/	/	•
R08	Attacchi 1/2 G BSPP (36x36) 1/2 G BSPP (36x36) Main Ports	/	•	/

• Disponibile - Available / Non Disponibile - Not Available

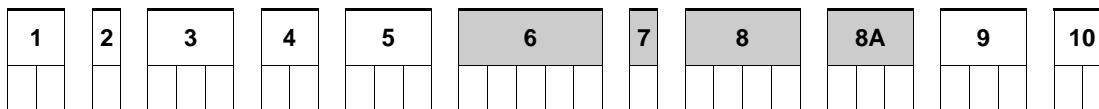

## 6 - ESTREMITÀ ALBERO / OUTPUT SHAFT

CL250	Albero Cilindrico Ø25 mm 0.984 in Parallel keyed	STANDARD
CL254	Albero Cilindrico Ø25.4 mm 1 in Parallel keyed	
SD250	Albero Scanalato (profilo SAE 6B 1" Z6) Splined Shaft (SAE 6B 1" 6T spline)	

## 7 - TENUTE / SEALS

N	NBR	STANDARD
V	FKM	

## 8 - VALVOLE / VALVES

			ATTACCHI / MAIN PORTS		
			M08	F08	R08
XXXX	Non Richieste Not Required	STANDARD	●	●	●
M081	Valvola di massima pressione VAF 08 - D VAF 08 - D pressure relief valve		●	/	/
M082	Valvola di massima pressione VAF 08 - D/AF VAF 08 - D/AF pressure relief valve		●	/	/
M083	Valvola Antiurto e Anticavitazione VAAF 31 VAAF 31 anticavitation and Anti-Shock Valve		●	/	/
M084	Valvola con prelievo del fluido in pressione AF AF shuttle-valve		●	/	/
M085	Valvola bilanciata di blocco e controllo discesa VCD 08 - S/AF VCD 08 - S/AF overcentre Valve		●	/	/
M086	Valvola di controllo bilanciata a doppio effetto VCR1 08 - D/AF VCR1 08 - D/AF double-acting overcentre valve with shuttle valve		●	/	/
M087	Valvola di controllo bilanciata a doppio effetto con valvola limitatrice di pressione VCR1 08 D/AF LDP VCR1 08 D/AF LDP double-acting overcentre valve with shuttle valve		●	/	/
M088	Rotodeviatore DR 08/R DR 08/R rotary switch		●	/	/

● Disponibile - Available / Non Disponibile - Not Available

## 8A - CARATTERISTICA VALVOLA / VALVES FEATURE

			VALVOLE / VALVES								
			XXXX	M081	M082	M083	M084	M085	M086	M087	M088
000	Caratteristica non necessaria Feature not necessary	STANDARD	●	/	/	/	●	/	/	/	/
001	Non Tarata (Campo Taratura 30÷70 bar) Not Set [435 to 1015 psi]		/	●	●	/	/	/	/	/	/
002	Non Tarata (Campo Taratura 70÷200 bar) Not Set [1015 to 2900 psi]		/	●	●	/	/	/	/	/	/
003	Non Tarata (Campo Taratura 50÷130 bar) Not Set [725 to 1885 psi]		/	/	/	●	/	/	/	/	/
004	Non Tarata (Campo Taratura 100÷250 bar) Not Set [1450 to 3625 psi]		/	/	/	●	/	/	/	/	/
005	Non Tarata (Campo Taratura 50÷150 bar) Not Set [725 to 2175 psi]		/	/	/	/	/	/	/	/	●
425	Rapporto di Pilotaggio 4.25:1 Pilot Ratio 4.25:1		/	/	/	/	/	●	●	/	/
800	Rapporto di Pilotaggio 8:1 Pilot Ratio 8:1		/	/	/	/	/	/	●	●	/
70D	Rapporto di Pilotaggio 7:1 - Senso di rotazione DX Pilot Ratio 7:1 - Direction of rotation CW		/	/	/	/	/	●	/	/	/
35D	Rapporto di Pilotaggio 3.5:1 -- Senso di rotazione DX Pilot Ratio 3.5:1 -- Direction of rotation CW		/	/	/	/	/	●	/	/	/
70S	Rapporto di Pilotaggio 7:1 - Senso di rotazione SX Pilot Ratio 7:1 - Direction of rotation CCW		/	/	/	/	/	●	/	/	/
35S	Rapporto di Pilotaggio 3.5:1 -- Senso di rotazione SX Pilot Ratio 3.5:1 -- Direction of rotation CCW		/	/	/	/	/	●	/	/	/

● Disponibile - Available / Non Disponibile - Not Available

Per la fornitura di valvole tarate contattare Uff. Tecnico.  
Please contact Technical department for valve which require specific setting

1	2	3	4	5	6	7	8	8A	9	10

## 9 - CARATTERISTICA VERSIONE / VERSION FEATURE

			VERSIONI / VERSIONS		
			S	E	P
<b>XXX</b>	Non Richiesta Not Required	STANDARD	•	•	•
<b>HPS</b>	Guarnizione alta pressione High Pressure Seal		•	•	•
<b>TC1</b>	Tachimetro TAC/U (Senza sensore) TAC/U tachometer (Without sensor)		•	/	/
<b>SV0</b>	Versione senza valvole di drenaggio interne Version without built-in check valves		/	•	/
<b>SVH</b>	Versione senza valvole di drenaggio interne + Guarnizione alta pressione Version without built-in check valves + High Pressure Seal		/	•	/
<b>SVA</b>	Versione senza valvole di drenaggio interne + Guarnizione alta pressione + Drenaggio posteriore - 1/4 G (BSPP) Version without built-in check valves + High Pressure Seal + Rear Drain - 1/4 G (BSPP)		/	•	/
<b>DPH</b>	Guarnizione alta pressione + Drenaggio posteriore - 1/4 G (BSPP) High Pressure Seal + Rear Drain - 1/4 G (BSPP)		•	/	/

• Disponibile - Available / Non Disponibile - Not Available

## 10 - OPZIONI / OPTIONS

<b>XX</b>	Non Richieste Not Required	STANDARD
<b>01</b>	Verniciato Nero RAL 9005 Black Painted RAL 9005	
<b>02</b>	Verniciato Blu RAL 5015 Blue Painted RAL 5015	
<b>06</b>	Verniciato Grigio RAL 7015 Grey Painted RAL 7015	
<b>07</b>	Verniciato Grigio RAL 7021 Grey Painted RAL 7021	

**DATI TECNICI PER MOTORE BG CON ALBERI CL250-CL254**  
**BG MOTOR TECHNICAL DATA WITH CL250-CL254 PARALLEL KEYS SHAFT**

Motore Motor	Cilindrata Displacement	Pressione max ingresso Max. input pressure		Pressione diff. max. Max. differential pressure		Coppia max. Max. torque		Portata max. Max. flow		Velocità max. Max. speed		Potenza max. Max. horsepower	
	cm <sup>3</sup> /rev [in <sup>3</sup> /rev]	bar [psi]		bar [psi]		Nm [lbf-ft]		l/min [U.S. gpm]		giri/min [rpm]		kW [hp]	
<b>BG 050</b>	49 [2.99]	Cont Int <sup>(1)</sup> Peak <sup>(2)</sup>	165 [2392] 200 [2900] 225 [3262]	Cont Int <sup>(1)</sup> Peak <sup>(2)</sup>	140 [2030] 175 [2540] 225 [3262]	Cont Int <sup>(1)</sup>	93 [68.5] 120 [88.4]	Cont Int <sup>(1)</sup>	60 [15.9] 75 [19.8]	Cont Int <sup>(1)</sup>	1220 1530	Cont Int <sup>(1)</sup>	10 [13.4] 12 [16.1]
<b>BG 080</b>	73 [4.45]	Cont Int <sup>(1)</sup> Peak <sup>(2)</sup>	165 [2392] 200 [2900] 225 [3262]	Cont Int* Int <sup>(1)</sup> Peak <sup>(2)</sup>	140 [2030] 175 [2540] 225 [3262]	Cont Int*	140 [103.1] 175 [128.9]	Cont Int <sup>(1)</sup>	60 [15.9] 75 [19.8]	Cont Int <sup>(1)</sup>	820 1025	Cont Int <sup>(1)</sup>	9.5 [12.7] 12 [16.1]
<b>BG 100</b>	101 [6.16]	Cont Int <sup>(1)</sup> Peak <sup>(2)</sup>	165 [2392] 200 [2900] 225 [3262]	Cont Int <sup>(1)</sup> Peak <sup>(2)</sup>	140 [2030] 175 [2540] 225 [3262]	Cont Int <sup>(1)</sup>	190 [140] 230 [169.5]	Cont Int <sup>(1)</sup>	60 [15.9] 75 [19.8]	Cont Int <sup>(1)</sup>	590 740	Cont Int <sup>(1)</sup>	10.5 [14] 13 [17.4]
<b>BG 130</b>	128 [7.80]	Cont Int <sup>(1)</sup> Peak <sup>(2)</sup>	165 [2392] 200 [2900] 225 [3262]	Cont Int <sup>(1)</sup> Peak <sup>(2)</sup>	140 [2030] 175 [2540] 225 [3262]	Cont Int <sup>(1)</sup>	240 [176.8] 290 [213.7]	Cont Int <sup>(1)</sup>	60 [15.9] 75 [19.8]	Cont Int <sup>(1)</sup>	465 585	Cont Int <sup>(1)</sup>	10 [13.4] 12 [16.1]
<b>BG 160</b>	168 [10.24]	Cont Int <sup>(1)</sup> Peak <sup>(2)</sup>	165 [2392] 200 [2900] 225 [3262]	Cont Int <sup>(1)</sup> Peak <sup>(2)</sup>	140 [2030] 175 [2540] 225 [3262]	Cont Int <sup>(1)</sup>	300 [221.1] 370 [272.6]	Cont Int <sup>(1)</sup>	60 [15.9] 75 [19.8]	Cont Int <sup>(1)</sup>	355 445	Cont Int <sup>(1)</sup>	10 [13.4] 12 [16.1]
<b>BG 200</b>	195 [11.89]	Cont Int <sup>(1)</sup> Peak <sup>(2)</sup>	165 [2392] 200 [2900] 225 [3262]	Cont Int <sup>(1)</sup> Peak <sup>(2)</sup>	115 [1670] 160 [2320] 200 [2900]	Cont Int <sup>(1)</sup>	300 [221.1] 390 [287.4]	Cont Int <sup>(1)</sup>	60 [15.9] 75 [19.8]	Cont Int <sup>(1)</sup>	305 380	Cont Int <sup>(1)</sup>	8 [10.7] 15 [20.1]
<b>BG 250</b>	244 [14.88]	Cont Int <sup>(1)</sup> Peak <sup>(2)</sup>	165 [2392] 195 [2827] 225 [3262]	Cont Int <sup>(1)</sup> Peak <sup>(2)</sup>	95 [1377] 125 [1810] 180 [2610]	Cont Int <sup>(1)</sup>	300 [221.1] 400 [294.8]	Cont Int <sup>(1)</sup>	60 [15.9] 75 [19.8]	Cont Int <sup>(1)</sup>	245 305	Cont Int <sup>(1)</sup>	6 [8.1] 8 [10.7]
<b>BG 315</b>	292 [17.81]	Cont Int <sup>(1)</sup> Peak <sup>(2)</sup>	165 [2392] 195 [2827] 225 [3262]	Cont Int <sup>(1)</sup> Peak <sup>(2)</sup>	80 [1160] 105 [1522] 160 [2320]	Cont Int <sup>(1)</sup>	300 [221.1] 400 [294.8]	Cont Int <sup>(1)</sup>	60 [15.9] 75 [19.8]	Cont Int <sup>(1)</sup>	205 255	Cont Int <sup>(1)</sup>	5 [6.7] 7 [9.4]
<b>BG 400</b>	390 [23.79]	Cont Int <sup>(1)</sup> Peak <sup>(2)</sup>	165 [2392] 195 [2827] 225 [3262]	Cont Int <sup>(1)</sup> Peak <sup>(2)</sup>	60 [870] 80 [1160] 130 [1890]	Cont Int <sup>(1)</sup>	300 [221.1] 400 [294.8]	Cont Int <sup>(1)</sup>	60 [15.9] 75 [19.8]	Cont Int <sup>(1)</sup>	150 190	Cont Int <sup>(1)</sup>	4 [5.4] 6 [8.1]

**DATI TECNICI PER MOTORE BG CON ALBERO SD250**  
**BG MOTOR TECHNICAL DATA WITH SD250 SPLINED SHAFT**

Motore Tipo Motor Type	Cilindrata Displacement	Pressione max ingresso Max. input pressure		Pressione diff. max. Max. differential pressure		Coppia max. Max. torque		Portata max. Max. flow		Velocità max. Max. speed		Potenza max. Max. horsepower	
	cm <sup>3</sup> /rev [in <sup>3</sup> /rev]	bar [psi]		bar [psi]		Nm [lbf-ft]		l/min [U.S. gpm]		giri/min [rpm]		kW [hp]	
<b>BG 050</b>	49 [2.99]	Cont Int <sup>(1)</sup> Peak <sup>(2)</sup>	165 [2392] 200 [2900] 225 [3262]	Cont Int <sup>(1)</sup> Peak <sup>(2)</sup>	140 [2030] 175 [2540] 225 [3262]	Cont Int <sup>(1)</sup>	93 [68.5] 120 [88.4]	Cont Int <sup>(1)</sup>	60 [15.9] 75 [19.8]	Cont Int <sup>(1)</sup>	1220 1530	Cont Int <sup>(1)</sup>	10 [13.4] 12 [16.1]
<b>BG 080</b>	73 [4.45]	Cont Int <sup>(1)</sup> Peak <sup>(2)</sup>	165 [2392] 200 [2900] 225 [3262]	Cont Int* Int <sup>(1)</sup> Peak <sup>(2)</sup>	140 [2030] 175 [2540] 225 [3262]	Cont Int*	140 [103.1] 175 [128.9]	Cont Int <sup>(1)</sup>	60 [15.9] 75 [19.8]	Cont Int <sup>(1)</sup>	820 1025	Cont Int <sup>(1)</sup>	9.5 [12.7] 12 [16.1]
<b>BG 100</b>	101 [6.16]	Cont Int <sup>(1)</sup> Peak <sup>(2)</sup>	165 [2392] 200 [2900] 225 [3262]	Cont Int <sup>(1)</sup> Peak <sup>(2)</sup>	140 [2030] 175 [2540] 225 [3262]	Cont Int <sup>(1)</sup>	190 [140] 230 [169.5]	Cont Int <sup>(1)</sup>	60 [15.9] 75 [19.8]	Cont Int <sup>(1)</sup>	590 740	Cont Int <sup>(1)</sup>	10.5 [14] 13 [17.4]
<b>BG 130</b>	128 [7.80]	Cont Int <sup>(1)</sup> Peak <sup>(2)</sup>	165 [2392] 200 [2900] 225 [3262]	Cont Int <sup>(1)</sup> Peak <sup>(2)</sup>	140 [2030] 175 [2540] 225 [3262]	Cont Int <sup>(1)</sup>	240 [176.8] 290 [213.7]	Cont Int <sup>(1)</sup>	60 [15.9] 75 [19.8]	Cont Int <sup>(1)</sup>	465 585	Cont Int <sup>(1)</sup>	10 [13.4] 12 [16.1]
<b>BG 160</b>	168 [10.24]	Cont Int <sup>(1)</sup> Peak <sup>(2)</sup>	165 [2392] 200 [2900] 225 [3262]	Cont Int <sup>(1)</sup> Peak <sup>(2)</sup>	140 [2030] 175 [2540] 225 [3262]	Cont Int <sup>(1)</sup>	300 [221.1] 370 [272.7]	Cont Int <sup>(1)</sup>	60 [15.9] 75 [19.8]	Cont Int <sup>(1)</sup>	355 445	Cont Int <sup>(1)</sup>	10 [13.4] 12 [16.1]
<b>BG 200</b>	195 [11.89]	Cont Int <sup>(1)</sup> Peak <sup>(2)</sup>	165 [2392] 200 [2900] 225 [3262]	Cont Int <sup>(1)</sup> Peak <sup>(2)</sup>	140 [2030] 175 [2540] 225 [3262]	Cont Int <sup>(1)</sup>	360 [265.3] 420 [309.5]	Cont Int <sup>(1)</sup>	60 [15.9] 75 [19.8]	Cont Int <sup>(1)</sup>	305 380	Cont Int <sup>(1)</sup>	10 [13.4] 12 [16.1]
<b>BG 250</b>	244 [14.88]	Cont Int <sup>(1)</sup> Peak <sup>(2)</sup>	165 [2392] 195 [2827] 225 [3262]	Cont Int <sup>(1)</sup> Peak <sup>(2)</sup>	110 [1595] 140 [2030] 180 [2610]	Cont Int <sup>(1)</sup>	360 [265.3] 440 [324.2]	Cont Int <sup>(1)</sup>	60 [15.9] 75 [19.8]	Cont Int <sup>(1)</sup>	245 305	Cont Int <sup>(1)</sup>	8 [10.7] 10 [13.4]
<b>BG 315</b>	292 [17.81]	Cont Int <sup>(1)</sup> Peak <sup>(2)</sup>	165 [2392] 195 [2827] 225 [3262]	Cont Int <sup>(1)</sup> Peak <sup>(2)</sup>	90 [1310] 115 [1667] 160 [2320]	Cont Int <sup>(1)</sup>	360 [265.3] 440 [324.2]	Cont Int <sup>(1)</sup>	60 [15.9] 75 [19.8]	Cont Int <sup>(1)</sup>	205 255	Cont Int <sup>(1)</sup>	5.6 [7.8] 7.5 [10.1]
<b>BG 400</b>	390 [23.79]	Cont Int <sup>(1)</sup> Peak <sup>(2)</sup>	165 [2392] 195 [2827] 225 [3262]	Cont Int <sup>(1)</sup> Peak <sup>(2)</sup>	70 [1020] 90 [1310] 130 [1890]	Cont Int <sup>(1)</sup>	360 [265.3] 440 [324.2]	Cont Int <sup>(1)</sup>	60 [15.9] 75 [19.8]	Cont Int <sup>(1)</sup>	150 190	Cont Int <sup>(1)</sup>	4.7 [6.3] 6 [8.1]

<b>MOTORE MOTOR</b>		<b>Press.max.scar.con dren. Max return pressure with drain line bar [psi]</b>	<b>Press.max.avviam.a vuoto Max starting pressure with no load bar [psi]</b>	<b>Coppia minima di spunto Min starting torque Nm [lbf ft]</b>		
<b>BG</b>	<b>050</b>	140 [2030]	10 [145]	A press. diff. max At max Δp	Cont. Int.	70 [51.6] 90 [66.3]
<b>BG</b>	<b>080</b>	140 [2030]	10 [145]	A press. diff. max At max Δp	Cont. Int.	105 [77.4] 135 [99.5]
<b>BG</b>	<b>100</b>	140 [2030]	10 [145]	A press. diff. max At max Δp	Cont. Int.	150 [111] 190 [140]
<b>BG</b>	<b>130</b>	140 [2030]	9 [131]	A press. diff. max At max Δp	Cont. Int.	190 [140] 240 [177]
<b>BG</b>	<b>160</b>	140 [2030]	8 [116]	A press. diff. max At max Δp	Cont. Int.	250 [184] 315 [232]
<b>BG</b>	<b>200</b>	140 [2030]	7 [102]	A press. diff. max At max Δp	Cont. Int.	255 [188] 320 [236]
<b>BG</b>	<b>250</b>	140 [2030]	6 [87]	A press. diff. max At max Δp	Cont. Int.	265 [195] 345 [254]
<b>BG</b>	<b>315</b>	140 [2030]	6 [87]	A press. diff. max At max Δp	Cont. Int.	250 [184] 330 [243]
<b>BG</b>	<b>400</b>	140 [2030]	6 [87]	A press. diff. max At max Δp	Cont. Int.	265 [195] 355 [262]

1) Le condizioni intermittenti non devono durare più del 10% di ogni minuto. Intermittent duty must not exceed 10% every minute.

2) Le condizioni di picco non devono durare più del 1% di ogni minuto. Peak duty must not exceed 1% of every minute.

Pressione massima di scarico senza drenaggio o massima pressione nella linea di drenaggio. I motori sono forniti nella versione con guarnizioni standard (diagramma Standard) o nella versione con guarnizioni ad alta pressione (diagramma HPS).

Per condizioni di pressione e velocità non contemplate dal presente grafico si consiglia di contattare la S.A.M. Hydraulik.  
 N.B.: Sulla versione TAC/U non è possibile installare guarnizioni HPS.

Max. return pressure without drain line or max. pressure in the drain line.

Motor are supplied in standard seal version (Standard chart) or in HPS seal version (HPS chart).

For pressure and speeds not showed in the curve below, please contact S.A.M. Hydraulik.

N.B.: TAC/U version is not available with HPS seals.

**STANDARD**

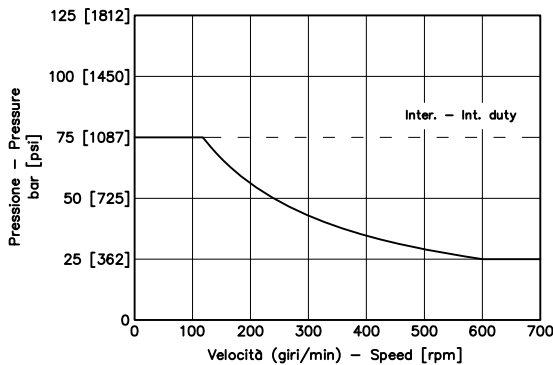

**HPS**

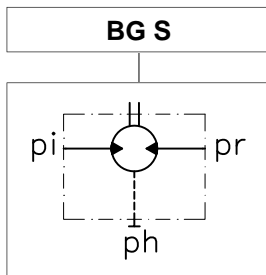
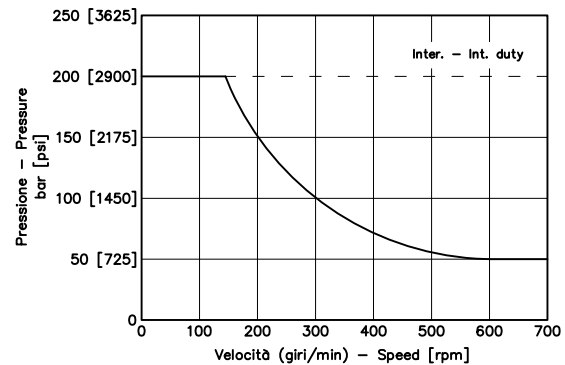

Nei motori BG S non sono presenti le valvole interne di drenaggio. La pressione sulla guarnizione (ph) è la media tra le pressioni di alimentazione e di scarico del motore. Se ph supera il valore consentito (vedi grafici in questa pagina), occorre aprire il drenaggio.

BG S motors don't feature built-in check valves. The (ph) pressure on the seal is the average between inlet and return pressure. If ph exceeds the allowed values (see the curves in this page), the drain line must be connected.

$$Ph = \frac{pi + pr}{2} [\text{bar}]$$

ph = pressione in carcassa      ph = housing pressure  
 pi = pressione di alimentazione      pi = inlet pressure  
 pr = pressione di scarico      pr = outlet pressure

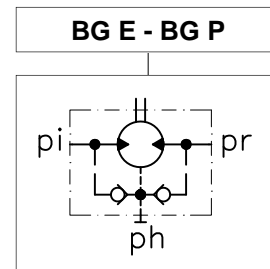

Nei motori BG E e BG P sono presenti le valvole interne di drenaggio. La pressione sulla guarnizione (ph) è uguale alla pressione di scarico del motore. Se ph supera il valore consentito (vedi grafici in questa pagina), occorre aprire il drenaggio.

BG E and BG P motors feature built-in check valves. The (ph) pressure on the seal is equal to the motor return pressure. If ph exceeds the allowed values (see the curves in this page), the drain line must be connected.



**Flangia 2A Flange**  
**Attacchi M08 Main ports**

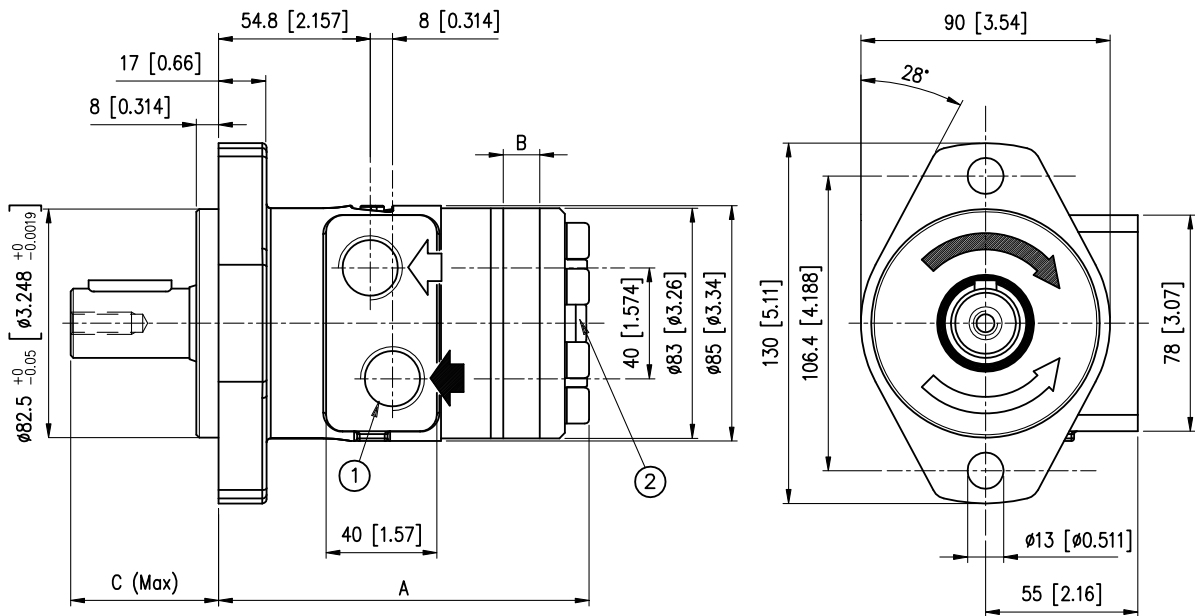

- 1) N° 2 fori di alimentazione 1/2 G (BSPP) profondità filetto 18 mm  
No. 2 1/2 G (BSPP) main ports thread depth 0.70 in
- 2) Drenaggio motore 1/4 G (BSPP) profondità filetto 12 mm  
1/4 G (BSPP) drain motor thread depth 0.472 in

Per le dimensioni degli alberi vedere pagina C/14  
For shafts dimensions see page C/14

ALBERO SHAFT		CL250	CL254	SD250						
C	mm [in]	53.5 [2.10]	53.5 [2.10]	53.5 [2.10]						

		BG S 050	BG S 080	BG S 100	BG S 130	BG S 160	BG S 200	BG S 250	BG S 315	BG S 400
A	mm [in]	127.5 [5.01]	130.5 [5.13]	134.5 [5.29]	138.5 [5.45]	143.5 [5.64]	146.5 [5.76]	153.5 [6.04]	162.5 [6.39]	172.5 [6.79]
B	mm [in]	6.3 [0.248]	9.5 [0.374]	13.3 [0.523]	16.2 [0.63]	21.9 [0.86]	25.5 [1.003]	31.7 [1.24]	38.1 [1.50]	50.8 [2.00]
Peso - Weight	kg [lb]	5.5 [12.1]	5.6 [12.3]	5.8 [12.8]	5.9 [13.0]	6.1 [13.4]	6.3 [13.9]	6.5 [14.3]	6.8 [15.0]	7.3 [16.1]

**Flangia S4 Flange**  
**Attacchi M08 Main ports**

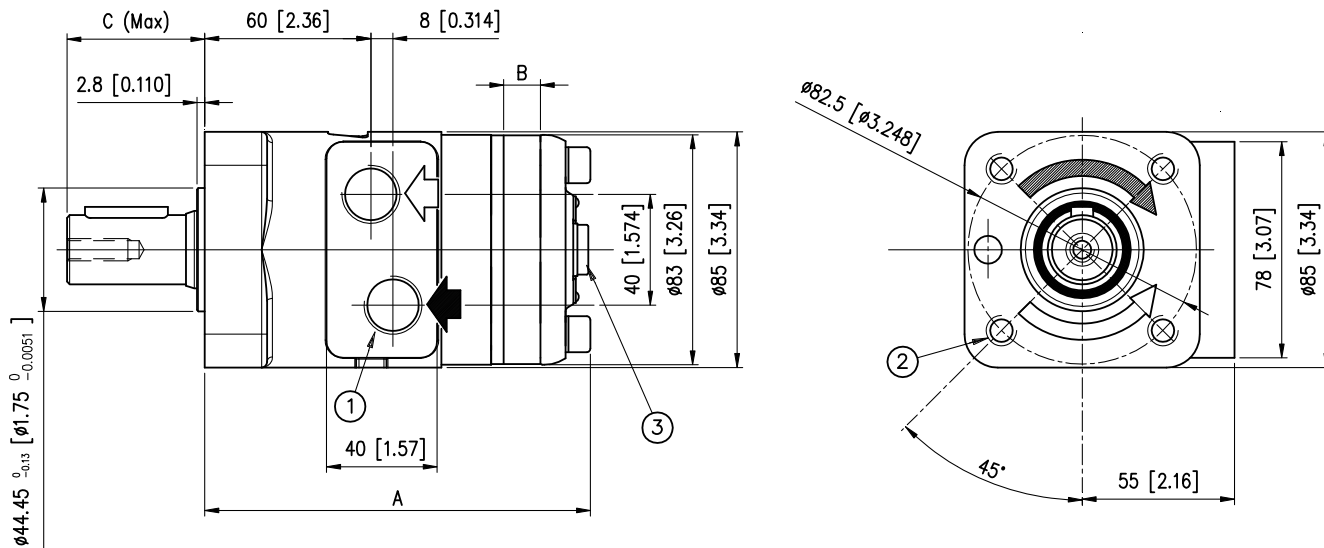

- 1) N° 2 fori di alimentazione 1/2 G (BSPP) profondità filetto 18 mm  
No. 2 1/2 G (BSPP) main ports thread depth 0.70 in
- 2) N° 4 3/8 16UNC profondità filetto 17 mm  
No. 4 3/8 16UNC thread depth 0.66 in
- 3) Drenaggio motore 1/4 G (BSPP) profondità filetto 12 mm  
1/4 G (BSPP) drain motor thread depth 0.472 in

Per le dimensioni degli alberi vedere pagina C/14  
For shafts dimensions see page C/14

ALBERO SHAFT		CL250	CL254	SD250						
C	mm [in]	50 [1.96]	45 [1.77]	50 [1.96]						
		<b>BG S 050</b>	<b>BG S 080</b>	<b>BG S 100</b>	<b>BG S 130</b>	<b>BG S 160</b>	<b>BG S 200</b>	<b>BG S 250</b>	<b>BG S 315</b>	<b>BG S 400</b>
A	mm [in]	133.1 [5.24]	136.3 [5.36]	140 [5.51]	143.7 [5.65]	148.7 [5.85]	152.2 [5.99]	158.5 [6.24]	165 [6.49]	177.5 [6.98]
B	mm [in]	6.3 [0.248]	9.5 [0.374]	13.3 [0.523]	16.2 [0.63]	21.9 [0.86]	25.5 [1.003]	31.7 [1.24]	38.1 [1.50]	50.8 [2.00]
Peso - Weight	kg [lb]	5.5 [12.1]	5.6 [12.3]	5.8 [12.8]	5.9 [13.0]	6.1 [13.4]	6.3 [13.9]	6.5 [14.3]	6.8 [15.0]	7.3 [16.1]

**Flangia 2A Flange**  
**Attacchi F08 Main ports**

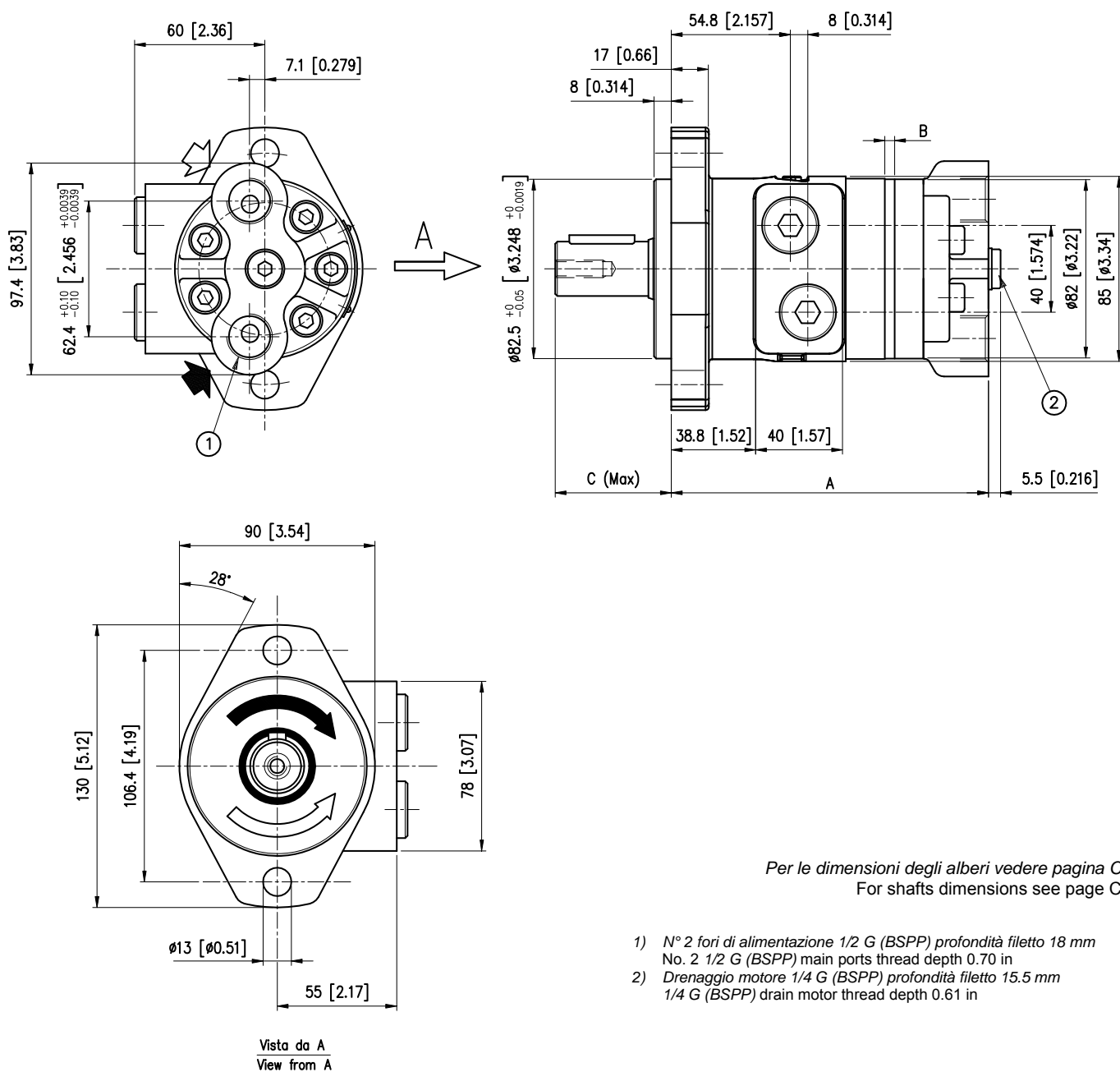

Per le dimensioni degli alberi vedere pagina C/14  
For shafts dimensions see page C/14

- 1) N° 2 fori di alimentazione 1/2 G (BSPP) profondità filetto 18 mm  
No. 2 1/2 G (BSPP) main ports thread depth 0.70 in
- 2) Drenaggio motore 1/4 G (BSPP) profondità filetto 15.5 mm  
1/4 G (BSPP) drain motor thread depth 0.61 in

ALBERO SHAFT		CL250	CL254	SD250						
C	mm [in]	53.5 [2.10]	53.5 [2.10]	53.5 [2.10]						
		<b>BG P 050</b>	<b>BG P 080</b>	<b>BG P 100</b>	<b>BG P 130</b>	<b>BG P 160</b>	<b>BG P 200</b>	<b>BG P 250</b>	<b>BG P 315</b>	<b>BG P 400</b>
A	mm [in]	140 [5.51]	143 [5.62]	147 [5.78]	150.2 [5.91]	155.5 [6.12]	159 [6.25]	165 [6.49]	171.5 [6.75]	187.5 [7.38]
B	mm [in]	6.3 [0.248]	9.5 [0.374]	13.3 [0.523]	16.2 [0.63]	21.9 [0.86]	25.5 [1.003]	31.7 [1.24]	38.1 [1.50]	50.8 [2.00]
Peso - Weight	kg [lb]	6.5 [14.3]	6.6 [14.5]	6.8 [15.0]	6.9 [15.2]	7.1 [15.6]	7.3 [16.1]	7.5 [16.5]	7.8 [17.2]	8.3 [18.3]

**Flangia 2A Flange**  
**Attacchi R08 Main ports**

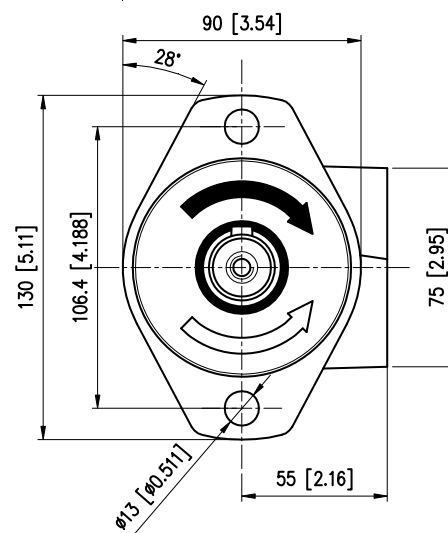
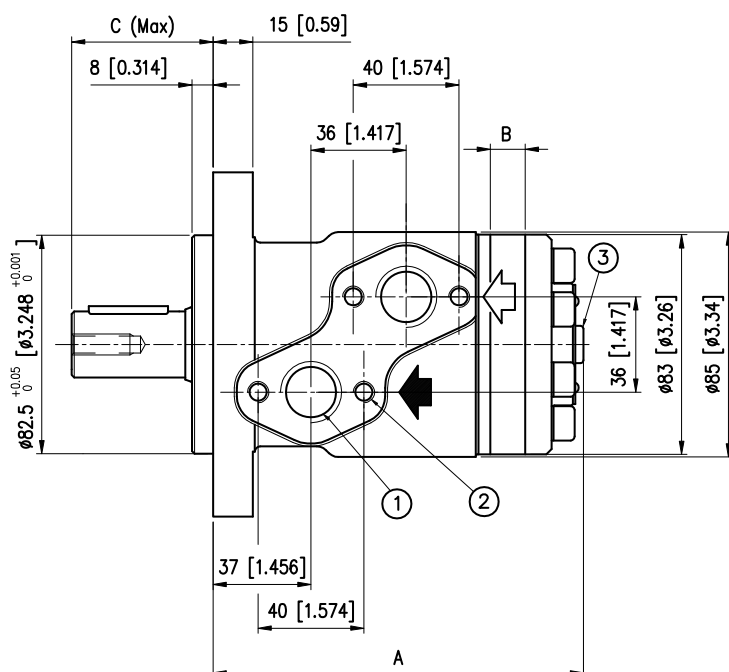

- 1) N° 2 fori di alimentazione 1/2 G (BSPP) profondità filetto 18 mm  
No. 2 1/2 G (BSPP) main ports thread depth 0.70 in
- 2) N° 4 fori M8 tratto utile filetto 16 mm  
No. 4 M8 thread depth 0.62 in
- 3) Drenaggio motore 1/4 G (BSPP) profondità filetto 12 mm  
1/4 G (BSPP) drain motor thread depth 0.472 in

*Per le dimensioni degli alberi vedere pagina C/14*  
*For shafts dimensions see page C/14*

ALBERO SHAFT		CL250	CL254	SD250						
C	mm [in]	55 [2.16]	50 [1.96]	55 [2.16]						
		<b>BG E 050</b>	<b>BG E 080</b>	<b>BG E 100</b>	<b>BG E 130</b>	<b>BG E 160</b>	<b>BG E 200</b>	<b>BG E 250</b>	<b>BG E 315</b>	<b>BG E 400</b>
A	mm [in]	135 [5.31]	138 [5.43]	142 [5.59]	146 [5.74]	151 [5.94]	154 [6.06]	161 [6.33]	167 [6.57]	180 [7.08]
B	mm [in]	6.3 [0.248]	9.5 [0.374]	13.3 [0.523]	16.2 [0.63]	21.9 [0.86]	25.5 [1.003]	31.7 [1.24]	38.1 [1.50]	50.8 [2.00]
Peso - Weight	kg [lb]	5.5 [12.1]	5.6 [12.3]	5.8 [12.8]	5.9 [13.0]	6.1 [13.4]	6.3 [13.9]	6.5 [14.3]	6.8 [15.0]	7.3 [16.1]

- 1) Drenaggio motore 1/4 G (BSPP) profondità filetto 12mm  
1/4 G (BSPP) drain motor thread depth 0.472 in
- 2) Attacco sensore M8x1  
Sensor connection M8x1

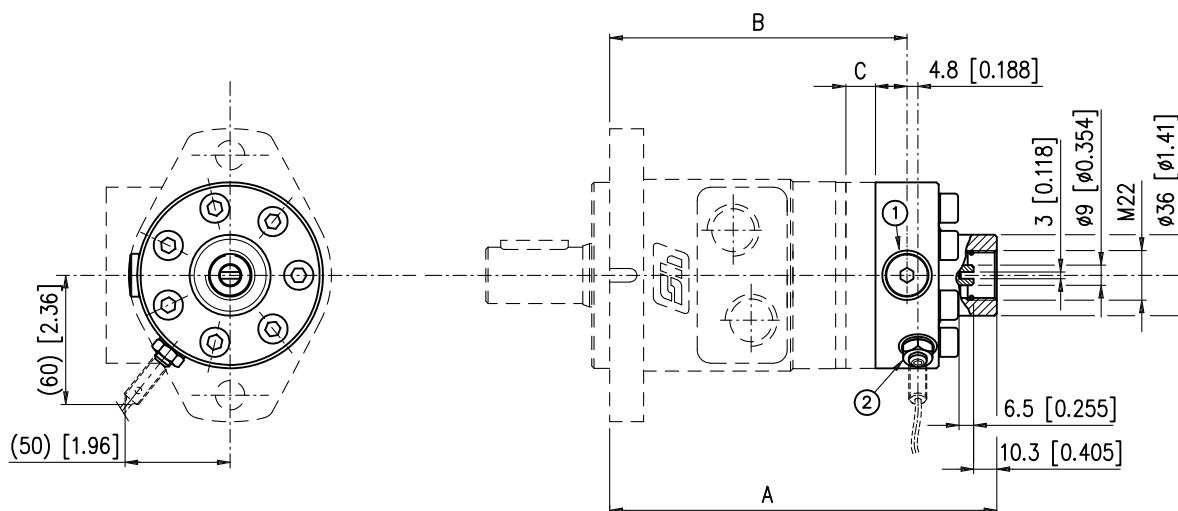

**ATTENZIONE:**

- L'alberino contagiri ha velocità pari a 6 volte quella dell'albero primario del motore e senso di rotazione opposto.
- N.B. Non sono accettati carichi assiali o radiali sull'albero contagiri. Coppia massima trasmissibile 1Nm.
- Il motore viene fornito senza il sensore elettronico: se necessario, richiederlo in fase di ordinazione.
- Pressione massima ammessa sulla guarnizione dell'albero contagiri con drenaggio chiuso: 25 bar.

**WARNING:**

- Tacho shaft has a 6 times higher revolution speed than the motor shaft and opposite direction of rotation.
- NOTE: Axial or radial load on tacho shaft must be avoided. Max torque on tacho 1 Nm [0.73 lbf-ft].
- The electronic sensor is not supplied: if required, please state it clearly on order form.
- Max pressure admissible on the shaft seal with closed drain port 25 bar [363 psi].

		BG S 050	BG S 080	BG S 100	BG S 130	BG S 160	BG S 200	BG S 250	BG S 315	BG S 400
<b>A</b>	<b>mm [in]</b>	163 [6.41]	166 [6.53]	170 [6.69]	174 [6.85]	179 [7.04]	182 [7.16]	189 [7.44]	195 [7.67]	208 [8.18]
<b>B</b>	<b>mm [in]</b>	123 [4.84]	126 [4.96]	130 [5.11]	134 [5.27]	139 [5.47]	142 [5.59]	149 [5.86]	155 [6.10]	168 [6.61]
<b>C</b>	<b>mm [in]</b>	6.3 [0.248]	9.5 [0.374]	13.3 [0.523]	16.2 [0.63]	21.9 [0.86]	25.5 [1.003]	31.7 [1.24]	38.1 [1.50]	50.8 [2.00]
<b>Peso - Weight</b>	<b>kg [lb]</b>	6 [13.2]	6.1 [13.4]	6.3 [13.9]	6.4 [14.1]	6.6 [14.5]	6.8 [15.0]	7.0 [15.4]	7.3 [16.1]	7.8 [17.2]

**CARATTERISTICHE TECNICHE DEL SENSORE ELETTRONICO**  
**ELECTRONIC SENSOR TECHNICAL FEATURES**

Segnale in uscita versione elettronica  
Output signal electronic tacho

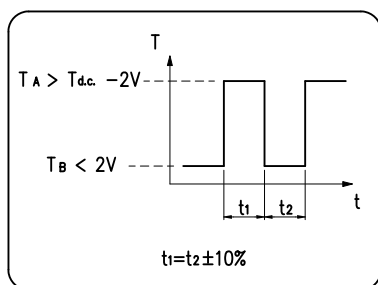

Numero d'impulsi per giro = 90  
Principio di funzionamento induttivo  
Funzione di uscita PNP  
Tensione nominale 10-65 V d.c.  
Caricabilità massima 300 mA  
Frequenza massima 10000 Hz  
Campo di temperatura -25C +85C  
Grado di protezione IP 67

Versioni disponibili:

- Sensore con cavo a tre fili lunghezza 2 metri (cod.424.0050.0000)
- Sensore con attacco per connettore tipo binder (cod.424.0060.0000) + connettore tipo binder
- con cavo a tre fili lunghezza 5 metri (cod.424.0080.0000)

Number of pulses per revolution = 90  
Inductive principle  
Output current PNP  
Voltage 10-65 V d.c.  
Max load 300 mA  
Max frequency 10000 Hz  
Temperature range -25C +85C  
Enclosure IP 67

Available versions:

- Sensor with 2 metres three wires cable (cod.424.0050.0000)
- Sensor with binder plug connection (cod.424.0060.0000) + binder connecting
- plug with 5 metres three wires cable (cod.424.0080.0000)

**ALBERO CILINDRICO CL250  
CL250 CYLINDRICAL SHAFT**

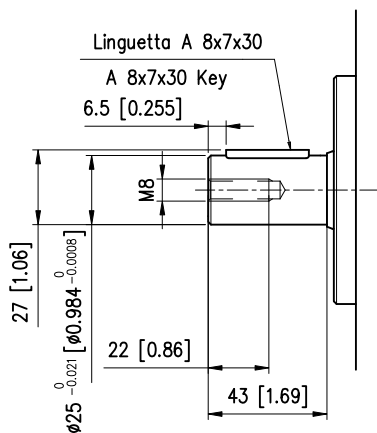

**ALBERO CILINDRICO CL254  
CL254 CYLINDRICAL SHAFT**

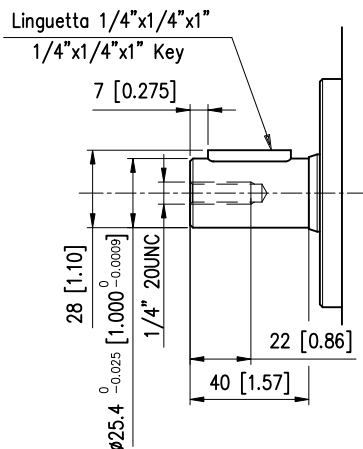

**ALBERO SCANALATO SD250  
SD250 SPLINED SHAFT**

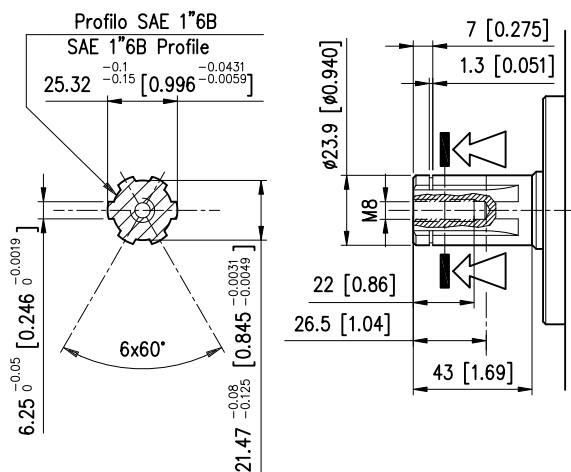

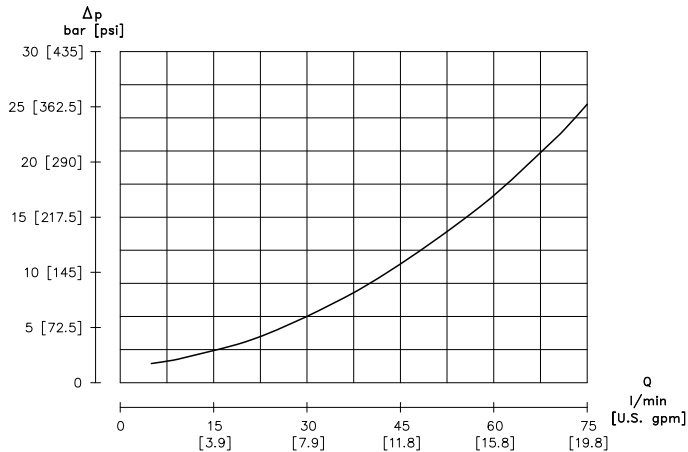

Il diagramma è stato ottenuto con prove eseguite su un numero significativo di motori, utilizzando un'olio avente una viscosità cinematica di 37 cSt alla temperatura di 45° C.

Diagram according to tests done with a huge number of motors and using hydraulic oil with kinematic viscosity of 37 cSt at 45° C temperature.

## CARICHI AMMESSI SULL'ALBERO SHAFT LOAD CAPACITY

I carichi ammessi sull'albero variano in funzione di:

- Velocità (n)
- Distanza (L) dal punto di applicazione del carico alla flangia di montaggio
- Versione della flangia di montaggio

Formula utilizzabile per il calcolo del carico radiale (Pr) ai vari numeri di giri (n), e alle varie distanze (L) dalla flangia tipo "2A" ovale 2 fori.

Radial load capacity (Pr) curve according to speed (n) and distance (L) from flange, valid for the 2-bolt flange type "2A"

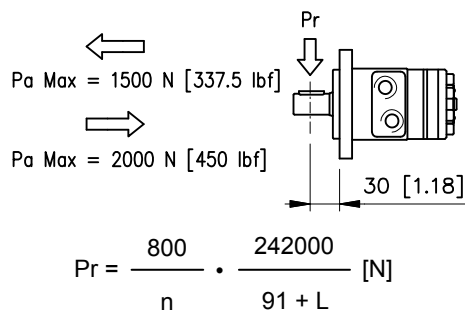

The permissible radial shaft load depends on

- Speed (n)
- Distance (L) from the point of load to the mounting flange
- Mounting flange version

Formula utilizzabile per il calcolo del carico radiale (Pr) ai vari numeri di giri (n), e alle varie distanze (L) dalla flangia tipo "S4" 4 fori.

Radial load capacity (Pr) curve according to speed (n) and distance (L) from flange, valid for the 4-bolt flange type "S4".

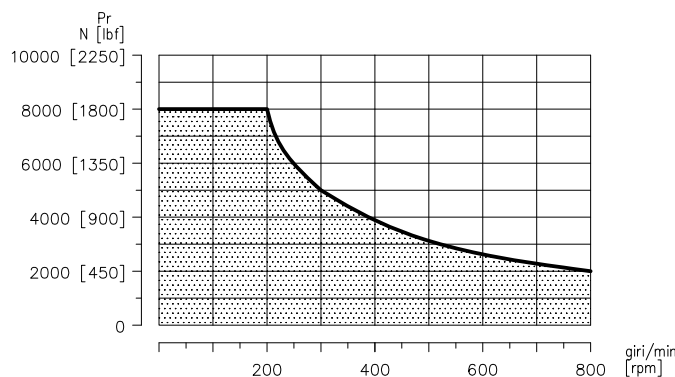
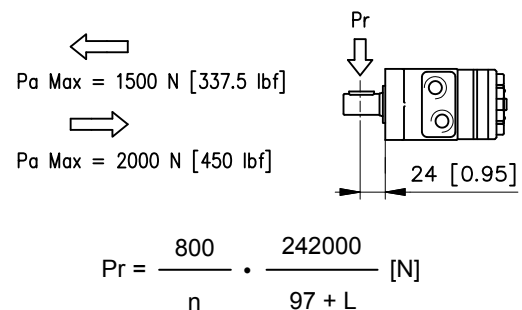

La curva mostra la relazione tra (Pr) e (n) quando:

- L= 30 mm [1.18 in] per motori flangia 2A
- L= 24 mm [0.95 in] per motori flangia S4

The curve shows the relation between (Pr) and (n)

- L= 30 mm [1.18 in] for motors with 2A flange
- L= 24 mm [0.95 in] for motors with S4 flange

Le seguenti lettere o numeri del codice, sono state sviluppate per identificare tutte le configurazioni possibili dei motori BH. Usare il seguente modulo per identificare le caratteristiche desiderate. **Tutte le lettere o numeri del codice devono comparire in fase d'ordine.** Si consiglia di leggere attentamente il catalogo prima di iniziare la compilazione del codice di ordinazione.

The following alphanumeric digits system has been developed to identify all of the configuration options for the BH motors. Use the model code below to specify the desired features. **All alphanumeric digits system of the code must be present when ordering.** We recommend to carefully read the catalogue before filling the ordering code.

**CODICE PRODOTTO / MODEL CODE**

1	2	3	4	5	6	7	8	8A	9	10

**1 - SERIE / SERIES**

BH	Motore orbitale Orbital motor
----	----------------------------------

**2 - VERSIONI / VERSIONS**

S	Versione S S Version
---	-------------------------

**3 - CILINDRATA / DISPLACEMENT**

050	49 cm <sup>3</sup> /giro [2.99 in <sup>3</sup> /rev]
080	73 cm <sup>3</sup> /giro [4.45 in <sup>3</sup> /rev]
100	101 cm <sup>3</sup> /giro [6.16 in <sup>3</sup> /rev]
130	128 cm <sup>3</sup> /giro [7.8 in <sup>3</sup> /rev]
160	168 cm <sup>3</sup> /giro [10.24 in <sup>3</sup> /rev]
200	195 cm <sup>3</sup> /giro [11.98 in <sup>3</sup> /rev]
250	244 cm <sup>3</sup> /giro [14.88 in <sup>3</sup> /rev]
315	292 cm <sup>3</sup> /giro [17.81 in <sup>3</sup> /rev]
400	390 cm <sup>3</sup> /giro [23.79 in <sup>3</sup> /rev]

**4 - FLANGIA / MOUNTING FLANGE**

6A	Ovale 6 Fori Oval 6 Bolts	STANDARD
S4	4 fori 3/8 16 UNC - Ø44,45mm 4 Bolt 3/8 16 UNC - Ø1.75 in	

**5 - ATTACCHI / MAIN PORTS**

S08	Attacchi 7/8" - 14 UNF SAE10 7/8" - 14 UNF SAE10 Main Ports	STANDARD
SS8	Attacchi 1/2" - 14 NPTF 1/2" - 14 NPTF Main Ports	
MS8	Attacchi G 1/2 BSPP G 1/2 BSPP Main Ports	
BFL	Attacchi Manifold Manifold Main Ports	



1	2	3	4	5	6	7	8	8A	9	10

### 6 - ESTREMITÀ ALBERO / OUTPUT SHAFT

CL254	Albero Cilindrico Ø25.4 mm 1 in Parallel keyed	STANDARD
CS254	Albero Cilindrico Ø25.4 mm foro spina 1 in Parallel crosshole	
SE250	Albero Scanalato (profilo SAE 6B 1" Z6) Splined Shaft (SAE 6B 1" 6T spline)	
SE210	Albero Scanalato (profilo ANSI-B92.1a-1976-16/32 Z13) Splined Shaft (ANSI-B92.1a-1976-16/32 13T spline)	Speciale a richiesta Special on request

### 7 - TENUTE / SEALS

N	NBR
---	-----

### 8 - VALVOLE / VALVES

XXXX	Non Richieste Not Required
------	-------------------------------

### 8A - CARATTERISTICA VALVOLA / VALVES FEATURE

000	Caratteristica non necessaria Feature not necessary
-----	--

### 9 - CARATTERISTICA VERSIONE / VERSION FEATURE

XXX	Guarnizione alta pressione High Pressure Seal
QDR	Versione QUAD-RING QUAD-RING Version
DPS	Guarnizione alta pressione con Drenaggio posteriore 1/4 G (BSPP) + Raccordo M/F 1/4 G (BSPP) - 7/16" 20UNF2B High Pressure Seal with Rear drain 1/4 G (BSPP) + Pipe Fitting M/F 1/4 G (BSPP) - 7/16" 20UNF2B
DPM	Guarnizione alta pressione con Drenaggio posteriore 1/4 G (BSPP) High Pressure Seal with Rear drain 1/4 G (BSPP)

### 10 - OPZIONI / OPTIONS

XX	Non Richieste Not Required
01	Verniciato Nero RAL 9005 Black Painted RAL 9005

**DATI TECNICI PER MOTORE BH CON ALBERO CL254-CS254 / BH MOTOR TECHNICAL DATA WITH CL254-CS254 SHAFT**

Motore Motor	Cilindrata Displacement	Pressione max ingresso Max. input pressure		Pressione diff. max. Max. differential pressure		Coppia max. Max. torque		Portata max. Max. flow		Velocità max. Max. speed		Potenza max. Max. horsepower	
	cm <sup>3</sup> /rev [in <sup>3</sup> /rev]	bar [psi]		bar [psi]		Nm [lbf-ft]		l/min [U.S. gpm]		giri/min [rpm]		kW [hp]	
<b>BH 050</b>	49 [2.99]	Cont Int <sup>1)</sup> Peak <sup>2)</sup>	165 [2392] 200 [2900] 225 [3262]	Cont Int <sup>1)</sup> Peak <sup>2)</sup>	140 [2030] 175 [2540] 225 [3262]	Cont Int <sup>1)</sup>	93 [68.5] 120 [88.4]	Cont Int <sup>1)</sup>	60 [15.9] 75 [19.8]	Cont Int <sup>1)</sup>	1220 1530	Cont Int <sup>1)</sup>	10 [13.4] 12 [16.1]
<b>BH 080</b>	73 [4.45]	Cont Int <sup>1)</sup> Peak <sup>2)</sup>	165 [2392] 200 [2900] 225 [3262]	Cont Int* Peak <sup>2)</sup>	140 [2030] 175 [2540] 225 [3262]	Cont Int*	140 [103.1] 175 [128.9]	Cont Int <sup>1)</sup>	60 [15.9] 75 [19.8]	Cont Int <sup>1)</sup>	820 1025	Cont Int <sup>1)</sup>	9.5 [12.7] 12 [16.1]
<b>BH 100</b>	101 [6.16]	Cont Int <sup>1)</sup> Peak <sup>2)</sup>	165 [2392] 200 [2900] 225 [3262]	Cont Int <sup>1)</sup> Peak <sup>2)</sup>	140 [2030] 175 [2540] 225 [3262]	Cont Int <sup>1)</sup>	190 [140] 230 [169.5]	Cont Int <sup>1)</sup>	60 [15.9] 75 [19.8]	Cont Int <sup>1)</sup>	590 740	Cont Int <sup>1)</sup>	10.5 [14] 13 [17.4]
<b>BH 130</b>	128 [7.80]	Cont Int <sup>1)</sup> Peak <sup>2)</sup>	165 [2392] 200 [2900] 225 [3262]	Cont Int <sup>1)</sup> Peak <sup>2)</sup>	140 [2030] 175 [2540] 225 [3262]	Cont Int <sup>1)</sup>	240 [176.8] 290 [213.7]	Cont Int <sup>1)</sup>	60 [15.9] 75 [19.8]	Cont Int <sup>1)</sup>	465 585	Cont Int <sup>1)</sup>	10 [13.4] 12 [16.1]
<b>BH 160</b>	168 [10.24]	Cont Int <sup>1)</sup> Peak <sup>2)</sup>	165 [2392] 200 [2900] 225 [3262]	Cont Int <sup>1)</sup> Peak <sup>2)</sup>	140 [2030] 175 [2540] 225 [3262]	Cont Int <sup>1)</sup>	300 [221.1] 370 [272.6]	Cont Int <sup>1)</sup>	60 [15.9] 75 [19.8]	Cont Int <sup>1)</sup>	355 445	Cont Int <sup>1)</sup>	10 [13.4] 12 [16.1]
<b>BH 200</b>	195 [11.89]	Cont Int <sup>1)</sup> Peak <sup>2)</sup>	165 [2392] 200 [2900] 225 [3262]	Cont Int <sup>1)</sup> Peak <sup>2)</sup>	115 [1670] 160 [2320] 200 [2900]	Cont Int <sup>1)</sup>	300 [221.1] 390 [287.4]	Cont Int <sup>1)</sup>	60 [15.9] 75 [19.8]	Cont Int <sup>1)</sup>	305 380	Cont Int <sup>1)</sup>	8 [10.7] 15 [20.1]
<b>BH 250</b>	244 [14.88]	Cont Int <sup>1)</sup> Peak <sup>2)</sup>	165 [2392] 195 [2827] 225 [3262]	Cont Int <sup>1)</sup> Peak <sup>2)</sup>	95 [1377] 125 [1810] 180 [2610]	Cont Int <sup>1)</sup>	300 [221.1] 400 [294.8]	Cont Int <sup>1)</sup>	60 [15.9] 75 [19.8]	Cont Int <sup>1)</sup>	245 305	Cont Int <sup>1)</sup>	6 [8.1] 8 [10.7]
<b>BH 315</b>	292 [17.81]	Cont Int <sup>1)</sup> Peak <sup>2)</sup>	165 [2392] 195 [2827] 225 [3262]	Cont Int <sup>1)</sup> Peak <sup>2)</sup>	80 [1160] 105 [1522] 160 [2320]	Cont Int <sup>1)</sup>	300 [221.1] 400 [294.8]	Cont Int <sup>1)</sup>	60 [15.9] 75 [19.8]	Cont Int <sup>1)</sup>	205 255	Cont Int <sup>1)</sup>	5 [6.7] 7 [9.4]
<b>BH 400</b>	390 (23.79)	Cont Int <sup>1)</sup> Peak <sup>2)</sup>	165 [2392] 195 [2827] 225 [3262]	Cont Int <sup>1)</sup> Peak <sup>2)</sup>	60 [870] 80 [1160] 130 [1890]	Cont Int <sup>1)</sup>	300 [221.1] 400 [294.8]	Cont Int <sup>1)</sup>	60 [15.9] 75 [19.8]	Cont Int <sup>1)</sup>	150 190	Cont Int <sup>1)</sup>	4 [5.4] 6 [8.1]

**DATI TECNICI PER MOTORE BH CON ALBERO SE250 / BH MOTOR TECHNICAL DATA WITH SE250 SHAFT**

Motore Motor	Cilindrata Displacement	Pressione max ingresso Max. input pressure		Pressione diff. max. Max. differential pressure		Coppia max. Max. torque		Portata max. Max. flow		Velocità max. Max. speed		Potenza max. Max. horsepower	
	cm <sup>3</sup> /rev [in <sup>3</sup> /rev]	bar [psi]		bar [psi]		Nm [lbf-ft]		l/min [U.S. gpm]		giri/min [rpm]		kW [hp]	
<b>BH 050</b>	49 [2.99]	Cont Int <sup>1)</sup> Peak <sup>2)</sup>	165 [2392] 200 [2900] 225 [3262]	Cont Int <sup>1)</sup> Peak <sup>2)</sup>	140 [2030] 175 [2540] 225 [3262]	Cont Int <sup>1)</sup>	93 [68.5] 120 [88.4]	Cont Int <sup>1)</sup>	60 [15.9] 75 [19.8]	Cont Int <sup>1)</sup>	1220 1530	Cont Int <sup>1)</sup>	10 [13.4] 12 [16.1]
<b>BH 080</b>	73 [4.45]	Cont Int <sup>1)</sup> Peak <sup>2)</sup>	165 [2392] 200 [2900] 225 [3262]	Cont Int* Peak <sup>2)</sup>	140 [2030] 175 [2540] 225 [3262]	Cont Int*	140 [103.1] 175 [128.9]	Cont Int <sup>1)</sup>	60 [15.9] 75 [19.8]	Cont Int <sup>1)</sup>	820 1025	Cont Int <sup>1)</sup>	9.5 [12.7] 12 [16.1]
<b>BH 100</b>	101 [6.16]	Cont Int <sup>1)</sup> Peak <sup>2)</sup>	165 [2392] 200 [2900] 225 [3262]	Cont Int <sup>1)</sup> Peak <sup>2)</sup>	140 [2030] 175 [2540] 225 [3262]	Cont Int <sup>1)</sup>	190 [140] 230 [169.5]	Cont Int <sup>1)</sup>	60 [15.9] 75 [19.8]	Cont Int <sup>1)</sup>	590 740	Cont Int <sup>1)</sup>	10.5 [14] 13 [17.4]
<b>BH 130</b>	128 [7.80]	Cont Int <sup>1)</sup> Peak <sup>2)</sup>	165 [2392] 200 [2900] 225 [3262]	Cont Int <sup>1)</sup> Peak <sup>2)</sup>	140 [2030] 175 [2540] 225 [3262]	Cont Int <sup>1)</sup>	240 [176.8] 290 [213.7]	Cont Int <sup>1)</sup>	60 [15.9] 75 [19.8]	Cont Int <sup>1)</sup>	465 585	Cont Int <sup>1)</sup>	10 [13.4] 12 [16.1]
<b>BH 160</b>	168 [10.24]	Cont Int <sup>1)</sup> Peak <sup>2)</sup>	165 [2392] 200 [2900] 225 [3262]	Cont Int <sup>1)</sup> Peak <sup>2)</sup>	140 [2030] 175 [2540] 225 [3262]	Cont Int <sup>1)</sup>	300 [221.1] 370 [272.7]	Cont Int <sup>1)</sup>	60 [15.9] 75 [19.8]	Cont Int <sup>1)</sup>	355 445	Cont Int <sup>1)</sup>	10 [13.4] 12 [16.1]
<b>BH 200</b>	195 [11.89]	Cont Int <sup>1)</sup> Peak <sup>2)</sup>	165 [2392] 200 [2900] 225 [3262]	Cont Int <sup>1)</sup> Peak <sup>2)</sup>	140 [2030] 175 [2540] 225 [3262]	Cont Int <sup>1)</sup>	360 [265.3] 420 [309.5]	Cont Int <sup>1)</sup>	60 [15.9] 75 [19.8]	Cont Int <sup>1)</sup>	305 380	Cont Int <sup>1)</sup>	10 [13.4] 12 [16.1]
<b>BH 250</b>	244 [14.88]	Cont Int <sup>1)</sup> Peak <sup>2)</sup>	165 [2392] 195 [2827] 225 [3262]	Cont Int <sup>1)</sup> Peak <sup>2)</sup>	110 [1595] 140 [2030] 180 [2610]	Cont Int <sup>1)</sup>	360 [265.3] 440 [324.2]	Cont Int <sup>1)</sup>	60 [15.9] 75 [19.8]	Cont Int <sup>1)</sup>	245 305	Cont Int <sup>1)</sup>	8 [10.7] 10 [13.4]
<b>BH 315</b>	292 [17.81]	Cont Int <sup>1)</sup> Peak <sup>2)</sup>	165 [2392] 195 [2827] 225 [3262]	Cont Int <sup>1)</sup> Peak <sup>2)</sup>	90 [1310] 115 [1667] 160 [2320]	Cont Int <sup>1)</sup>	360 [265.3] 440 [324.2]	Cont Int <sup>1)</sup>	60 [15.9] 75 [19.8]	Cont Int <sup>1)</sup>	205 255	Cont Int <sup>1)</sup>	5.6 [7.8] 7.5 [10.1]
<b>BH 400</b>	390 [23.79]	Cont Int <sup>1)</sup> Peak <sup>2)</sup>	165 [2392] 195 [2827] 225 [3262]	Cont Int <sup>1)</sup> Peak <sup>2)</sup>	70 [1020] 90 [1310] 130 [1890]	Cont Int <sup>1)</sup>	360 [265.3] 440 [324.2]	Cont Int <sup>1)</sup>	60 [15.9] 75 [19.8]	Cont Int <sup>1)</sup>	150 190	Cont Int <sup>1)</sup>	4.7 [6.3] 6 [8.1]

1) Le condizioni intermittenti non devono durare più del 10% di ogni minuto. Intermittent duty must not exceed 10% every minute.  
2) Le condizioni di picco non devono durare più del 1% di ogni minuto. Peak duty must not exceed 1% of every minute.

La pressione ammissibile in carcassa per versione HPS (standard) è riportata nel grafico. Elevate pressioni in carcassa comportano basse velocità dell'albero. Se la massima pressione in carcassa è elevata, è necessario utilizzare il drenaggio.  
Allowable case pressure for HPS version (standard) is showed in the diagram below - diagram based on case pressure and shaft speed. Allowable case pressure is highest at low shaft speed. If max. allowable case pressure is exceeded, case drain line is needed.

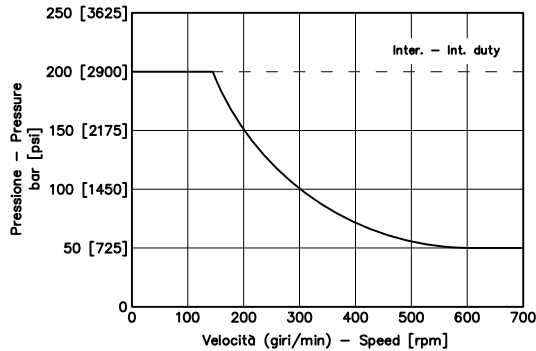

- La pressione in carcassa senza drenaggio è data dalla media tra  $p_i$  e  $p_r$ .
- Il motore BH è fornito senza drenaggio
- La massima pressione di scarico con drenaggio è di 138 bar Cont.

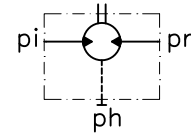

$$P_h = \frac{p_i + p_r}{2} [\text{bar}]$$

$p_h$  = pressione in carcassa  
 $p_i$  = pressione di alimentazione  
 $p_r$  = pressione di scarico

$p_h$  = housing pressure  
 $p_i$  = inlet pressure  
 $p_r$  = outlet pressure

- The case pressure without drain line is the average between inlet and return pressure.
- As standard, BH motors are supplied without drain port.
- Max. permissible return (back) pressure with drain line 138 bar [2000 psi] Cont.

**Flangia S4 Flange**

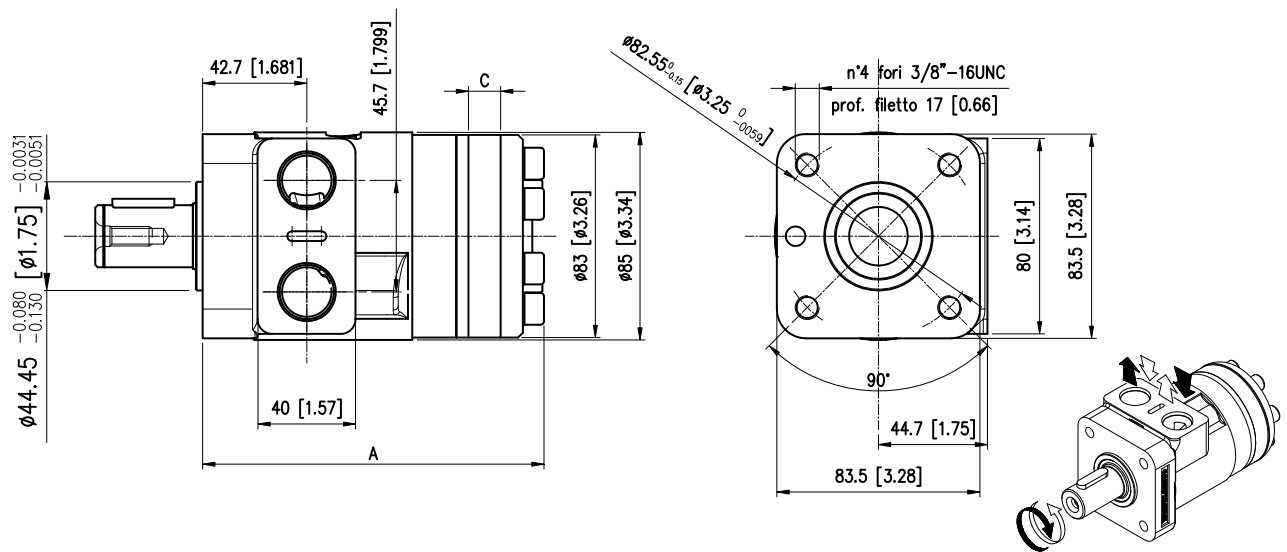

		BH 050	BH 080	BH 100	BH 130	BH 160	BH 200	BH 250	BH 315	BH 400
<b>A</b>	<b>mm [in]</b>	133.1 [5.24]	136.3 [5.36]	140 [5.51]	143.7 [5.65]	148.7 [5.85]	152.2 [5.99]	158.5 [6.24]	164.9 [6.49]	177.6 [6.99]
<b>C</b>	<b>mm [in]</b>	6.3 [0.248]	9.5 [0.374]	13.2 [0.519]	16.9 [0.66]	21.9 [0.86]	25.4 [1.00]	31.7 [1.24]	38.1 [1.50]	50.8 [2.00]
<b>Pesi - Weight</b>	<b>kg [lb]</b>	5.5 [12.12]	5.6 [12.34]	5.8 [12.78]	5.9 [13]	6 [13.4]	6.3 [13.88]	6.5 [14.3]	6.8 [14.98]	7.2 [16]

**Flangia 6A Flange**

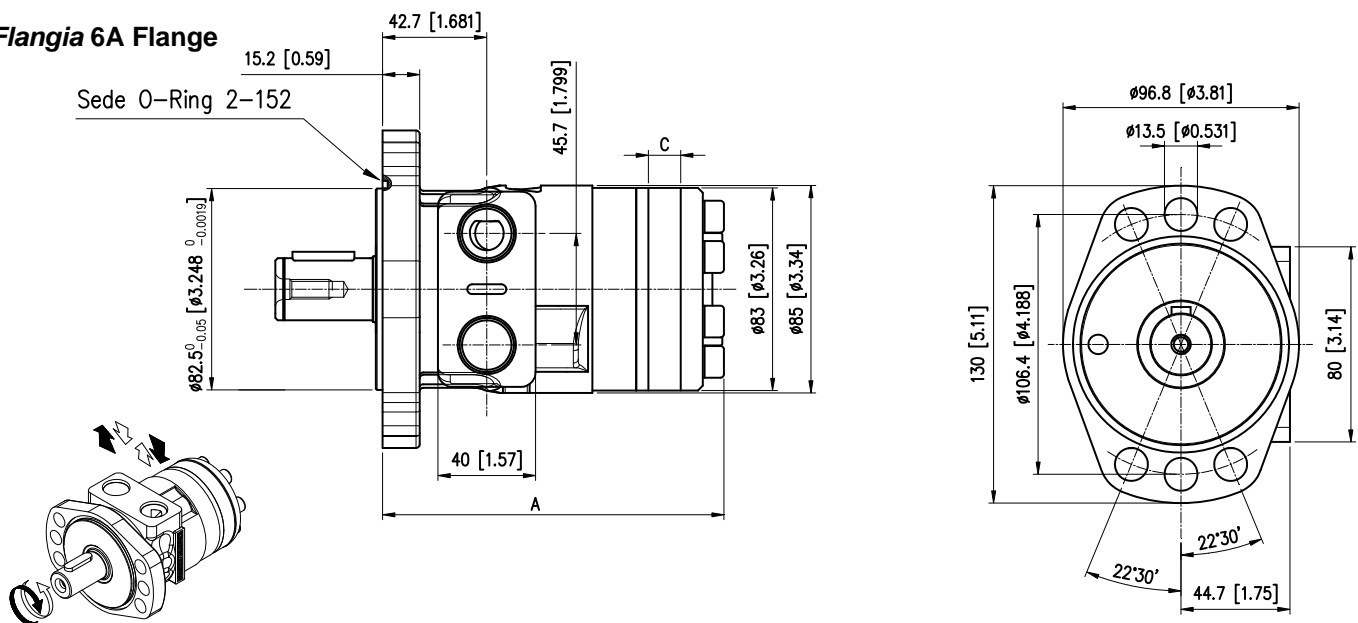

		BH 050	BH 080	BH 100	BH 130	BH 160	BH 200	BH 250	BH 315	BH 400
<b>A</b>	<b>mm [in]</b>	133.1 [5.24]	136.3 [5.36]	140 [5.51]	143.7 [5.65]	148.7 [5.85]	152.2 [5.99]	158.5 [6.24]	164.9 [6.49]	177.6 [6.99]
<b>C</b>	<b>mm [in]</b>	6.3 [0.248]	9.5 [0.374]	13.2 [0.519]	16.9 [0.66]	21.9 [0.86]	25.4 [1.00]	31.7 [1.24]	38.1 [1.50]	50.8 [2.00]
<b>Pesi - Weight</b>	<b>kg [lb]</b>	5.5 [12.12]	5.6 [12.34]	5.8 [12.78]	5.9 [13]	6 [13.4]	6.3 [13.88]	6.5 [14.3]	6.8 [14.98]	7.2 [16]

**Cilindrico CL254**  
**Parallel CL254**

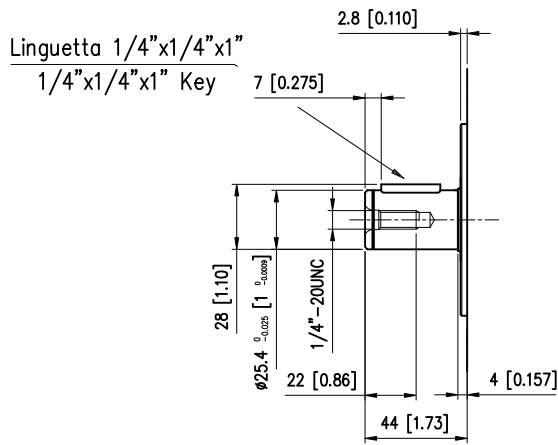

**Scanalato SE250**  
**Splined SE250**

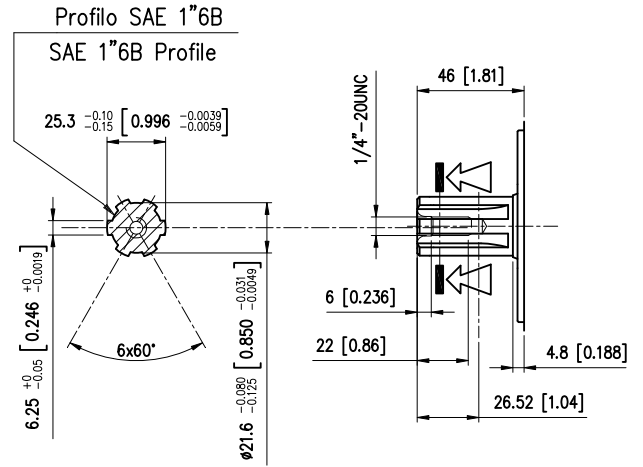

**Scanalato SE210 (Speciale a richiesta)**  
**Splined SE210 (Special on request)**

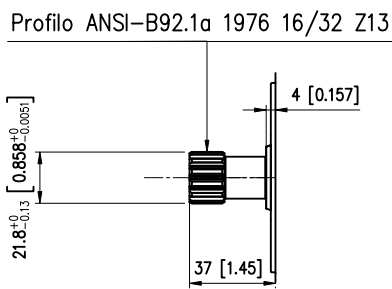

**Cilindrico CS254**  
**Parallel CS254**

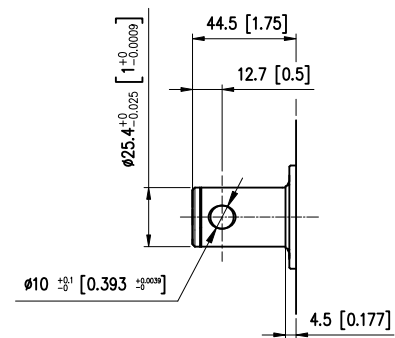

**ATTACCHI**  
**OPTIONS**

**MS8**

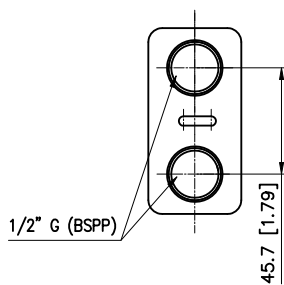

**SS8**

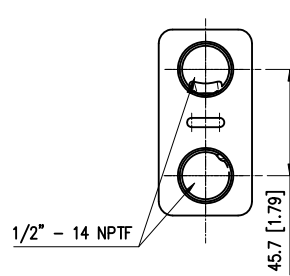

**Manifold (BFL)**

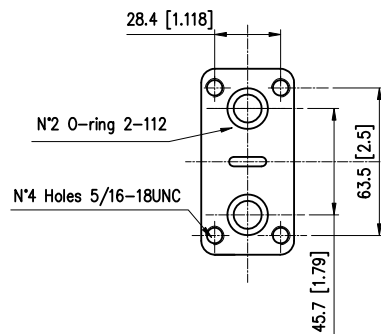

**S08**

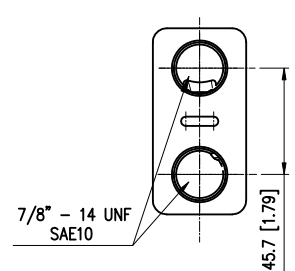

I carichi ammessi sull'albero variano in funzione di:

- Velocità (n)
- Distanza (L) dal punto di applicazione del carico alla flangia di montaggio
- Versione della flangia di montaggio

Formula utilizzabile per il calcolo del carico radiale (Pr) ai vari numeri di giri (n), e alle varie distanze (L) dalla flangia tipo "6A" ovale 6 fori.

Radial load capacity (Pr) cur ve according to speed (n) and distance (L) from flange, valid for the 6-bolt flange type "6A".

The permissible radial shaft load depends on

- Speed (n)
- Distance (L) from the point of load to the mounting flange
- Mounting flange version

Formula utilizzabile per il calcolo del carico radiale (Pr) ai vari numeri di giri (n), e alle varie distanze (L) dalla flangia tipo "S4" 4 fori.

Radial load capacity (Pr) cur ve according to speed (n) and distance (L) from flange, valid for the 4-bolt flange type "S4"

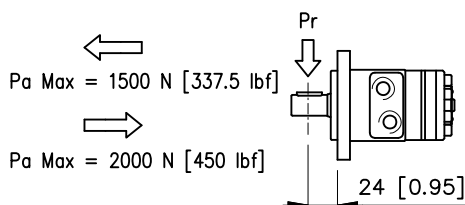

$$Pr = \frac{800}{n} \cdot \frac{242000}{97 + L} \text{ [N]}$$

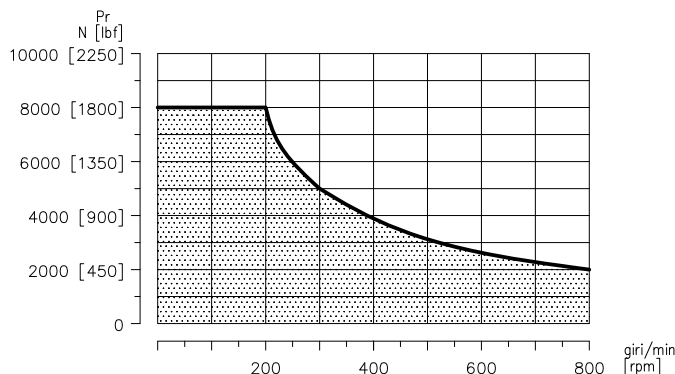
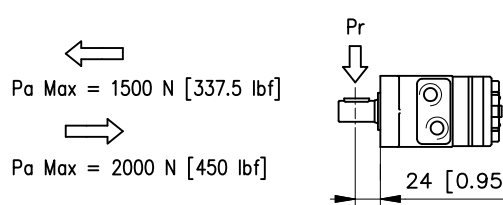

La curva mostra la relazione tra (Pr) e (n) quando:

- L= 24 mm [0.95 in] per motori flangia S4 e 6A

The curve show the relation between (Pr) and (n)

- L= 24 mm [0.95 in] for motors with S4 and 6A flange

## VERSIONE SPECIALE SPECIAL VERSION

DRENAGGIO POSTERIORE + RACCORDO M/F 1/4 G (BSPP) - 7/16" 20UNF2B  
REAR DRAIN + PIPE FITTING M/F 1/4 G (BSPP) - 7/16" 20UNF2B

Per i motori BH è possibile richiedere un attacco di drenaggio sul fondello.

Se si vuole predisporre il motore con l'attacco di drenaggio è necessario specificare in fase d'ordine il valore DPS (vedere punto 9 del codice di ordinazione).

For the BH motors, it is possible to put a drain port on the rear cover.

If it is necessary on the motor a drain port, to specify in the purchase order the value DPS (See position 9 of ordering code)

Versione disponibile per i motori con flangia: 6A - S4

Available on following Mounting flange motors: 6A - S4

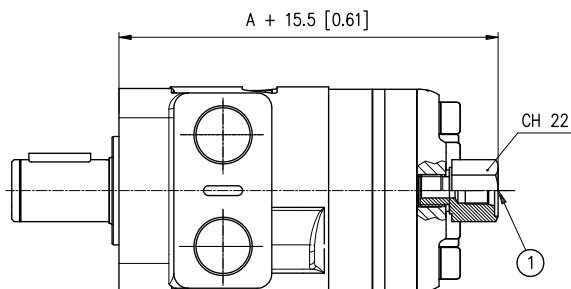

La quota "A" è riferita al dimensionale del motore senza raccordo .  
"A" dimension is related to motor length without pipe fitting.

1) Drenaggio motore 7/16" 20 UNF 2B profondità filetto 12 mm  
7/16" 20 UNF 2B drain motor thread depth 0.472 in

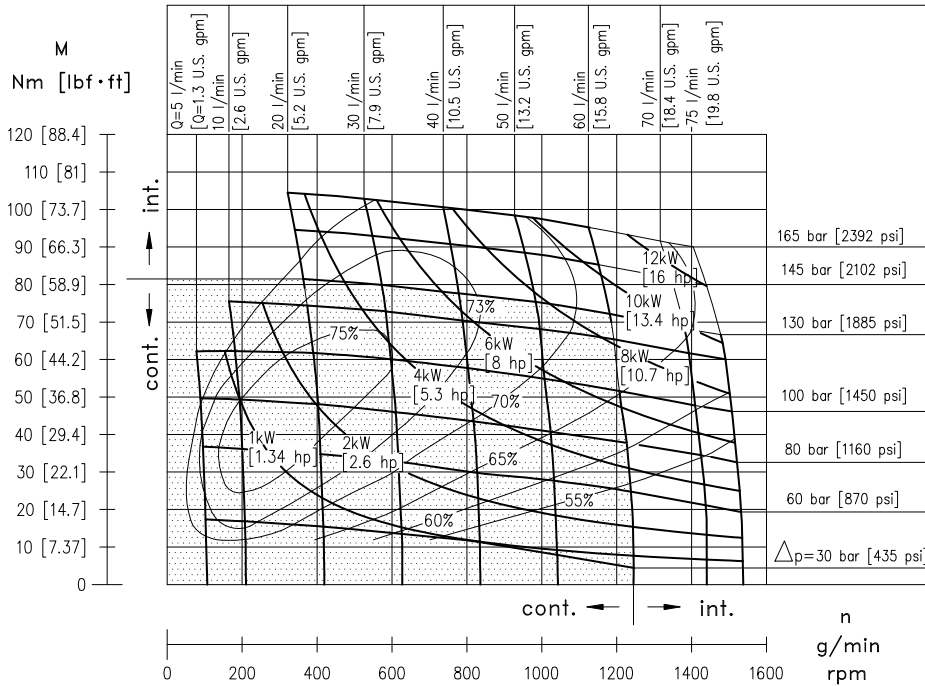

Pressioni e portate superiori a quelle ammesse in regime continuo non devono essere applicate contemporaneamente.

Exceeding continuous pressure values or exceeding flow values indicated, must not occur simultaneously.

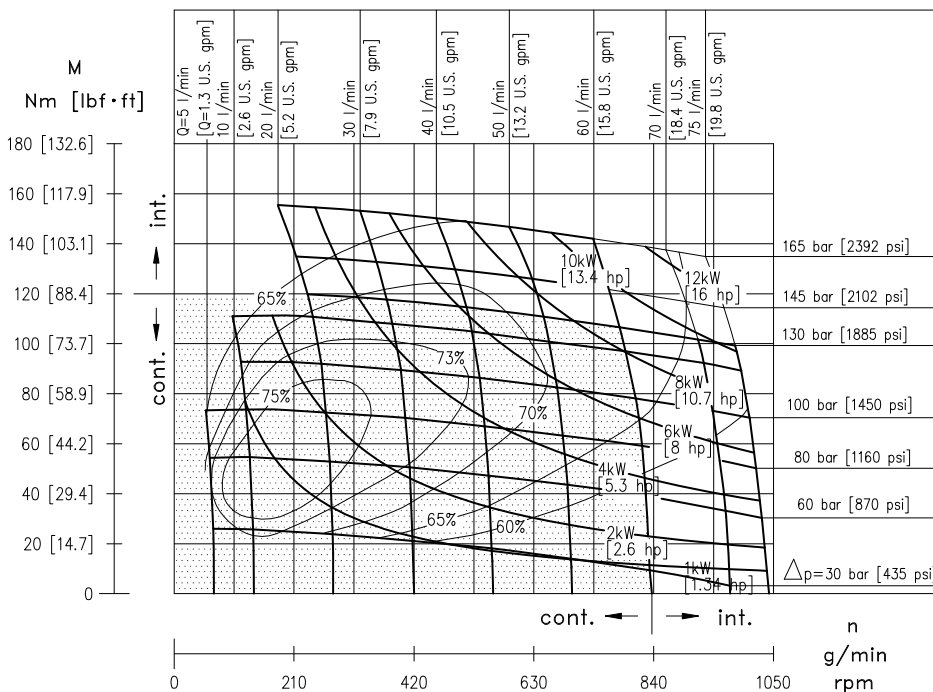

Pressioni e portate superiori a quelle ammesse in regime continuo non devono essere applicate contemporaneamente.

Exceeding continuous pressure values or exceeding flow values indicated, must not occur simultaneously.

# BG-BH 100

IN AGGIORNAMENTO  
TO BE UPDATED

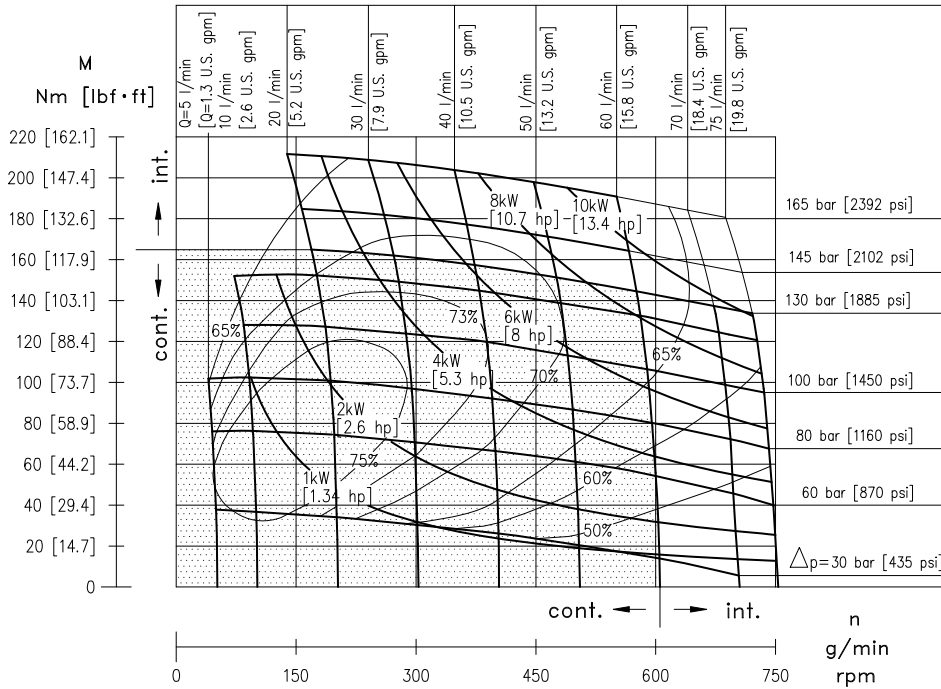

Pressioni e portate superiori a quelle ammesse in regime continuo non devono essere applicate contemporaneamente.  
Exceeding continuous pressure values or exceeding flow values indicated, must not occur simultaneously.

# BG-BH 130

IN AGGIORNAMENTO  
TO BE UPDATED

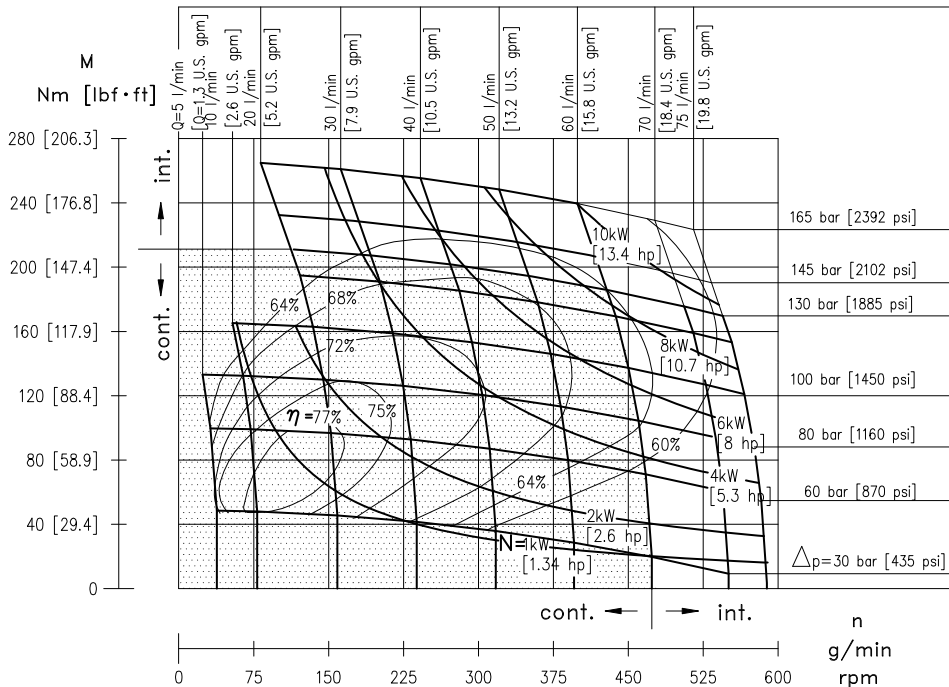

Pressioni e portate superiori a quelle ammesse in regime continuo non devono essere applicate contemporaneamente.  
Exceeding continuous pressure values or exceeding flow values indicated, must not occur simultaneously.



# BG-BH 160

IN AGGIORNAMENTO  
TO BE UPDATED

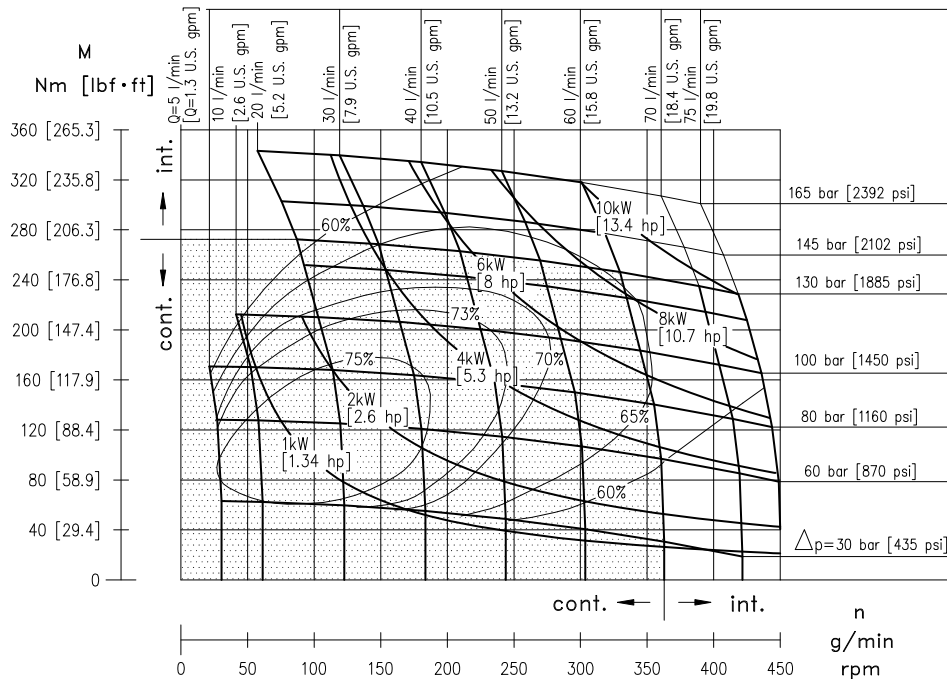

Pressioni e portate superiori a quelle ammesse in regime continuo non devono essere applicate contemporaneamente. Exceeding continuous pressure values or exceeding flow values indicated, must not occur simultaneously.

# BG-BH 200

IN AGGIORNAMENTO  
TO BE UPDATED

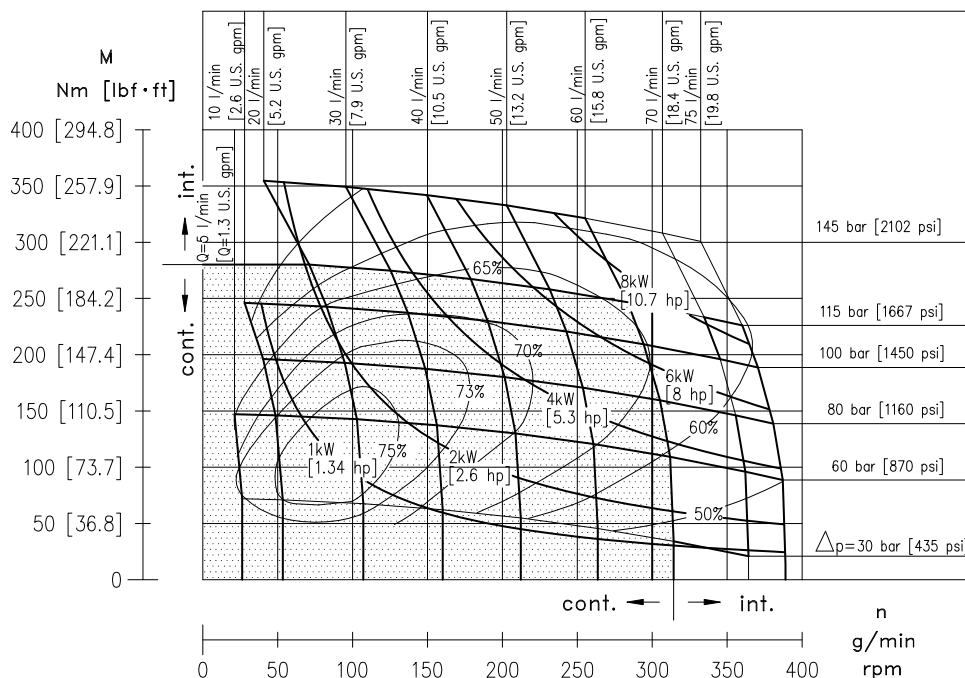

Pressioni e portate superiori a quelle ammesse in regime continuo non devono essere applicate contemporaneamente. Exceeding continuous pressure values or exceeding flow values indicated, must not occur simultaneously.

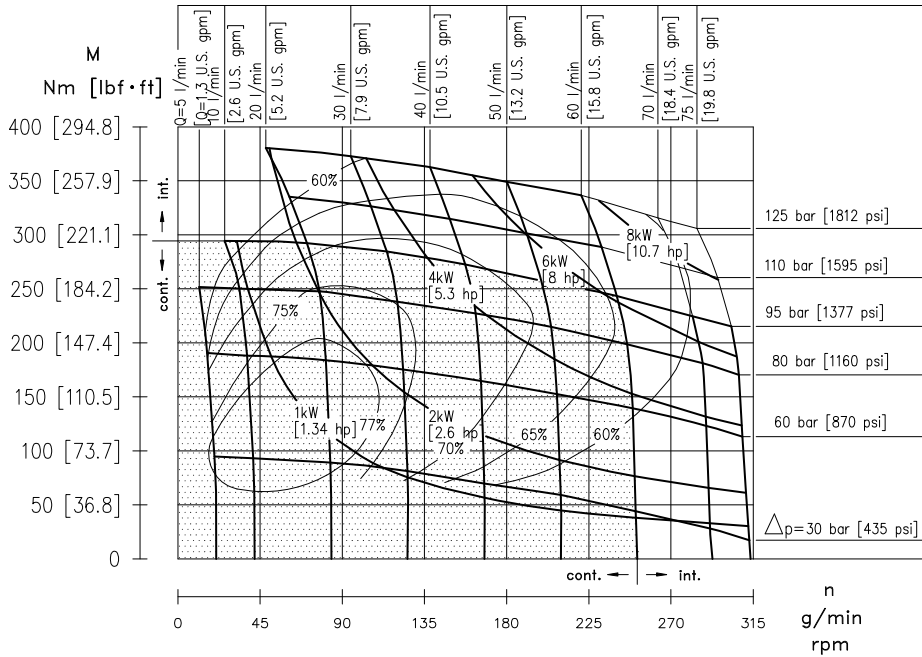

Pressioni e portate superiori a quelle ammesse in regime continuo non devono essere applicate contemporaneamente. Exceeding continuous pressure values or exceeding flow values indicated, must not occur simultaneously.

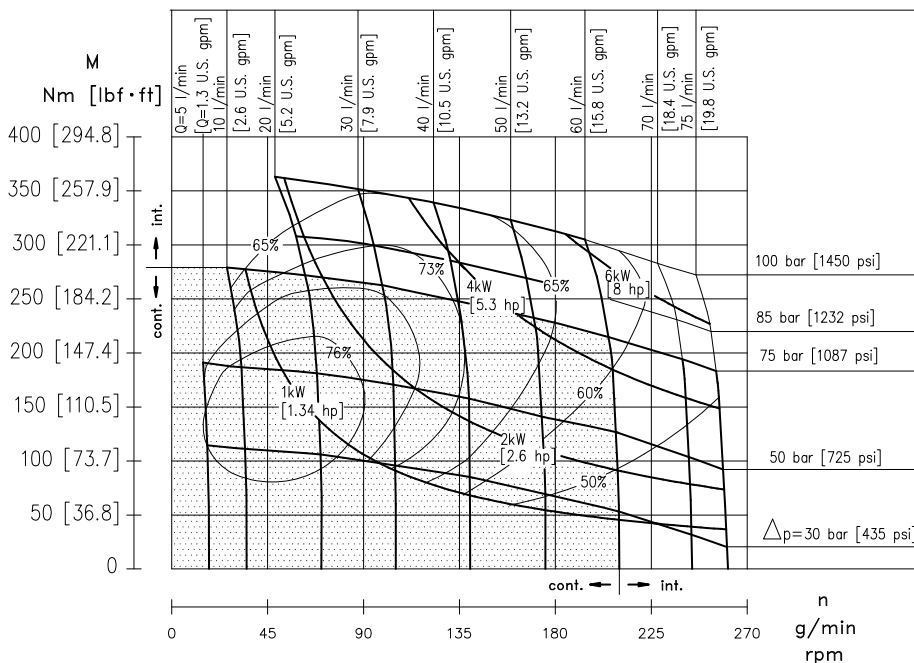

Pressioni e portate superiori a quelle ammesse in regime continuo non devono essere applicate contemporaneamente. Exceeding continuous pressure values or exceeding flow values indicated, must not occur simultaneously.

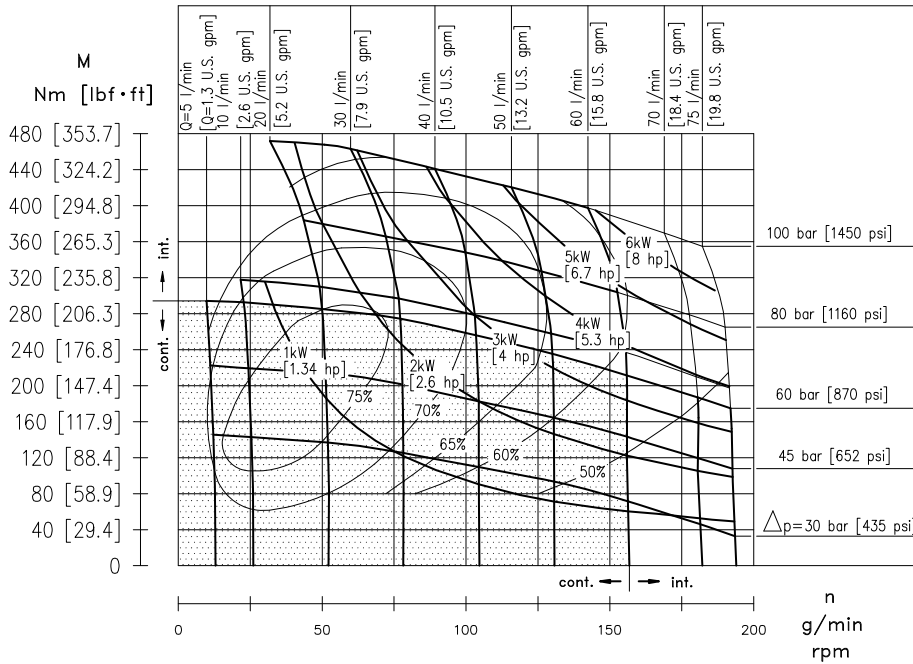

*Pressioni e portate superiori a quelle ammesse in regime continuo non devono essere applicate contemporaneamente.*  
Exceeding continuous pressure values or exceeding flow values indicated, must not occur simultaneously.

---

### **Informazioni sul prodotto**

*Dati i continui sviluppi, le modifiche e le migliorie al prodotto, la S.A.M. Hydraulik Spa non sarà responsabile per eventuali informazioni che possano indurre in errore, od erronee, riportate da cataloghi, istruzioni, disegni, dati tecnici e altri dati forniti dalla S.A.M. Hydraulik Spa. Non sarà possibile basare alcun procedimento legale su tale materiale.*

**Modifiche del prodotto.** La S.A.M. Hydraulik Spa si riserva il diritto di variare i suoi prodotti, anche quelli già ordinati, senza notifica.

### **Notice**

Due to the continuous product developments, modifications and improvements S.A.M. Hydraulik Spa will not be held responsible for any erroneous information or data that may lead to errors, indicated in catalogues, instructions, drawings, technical data and other data supplied by S.A.M. Hydraulik Spa. Therefore, legal actions cannot be based on such material. **Product development.** S.A.M. Hydraulik Spa reserves the right to make changes to its products, even for those already ordered, without notice.

---