

Technical
Information

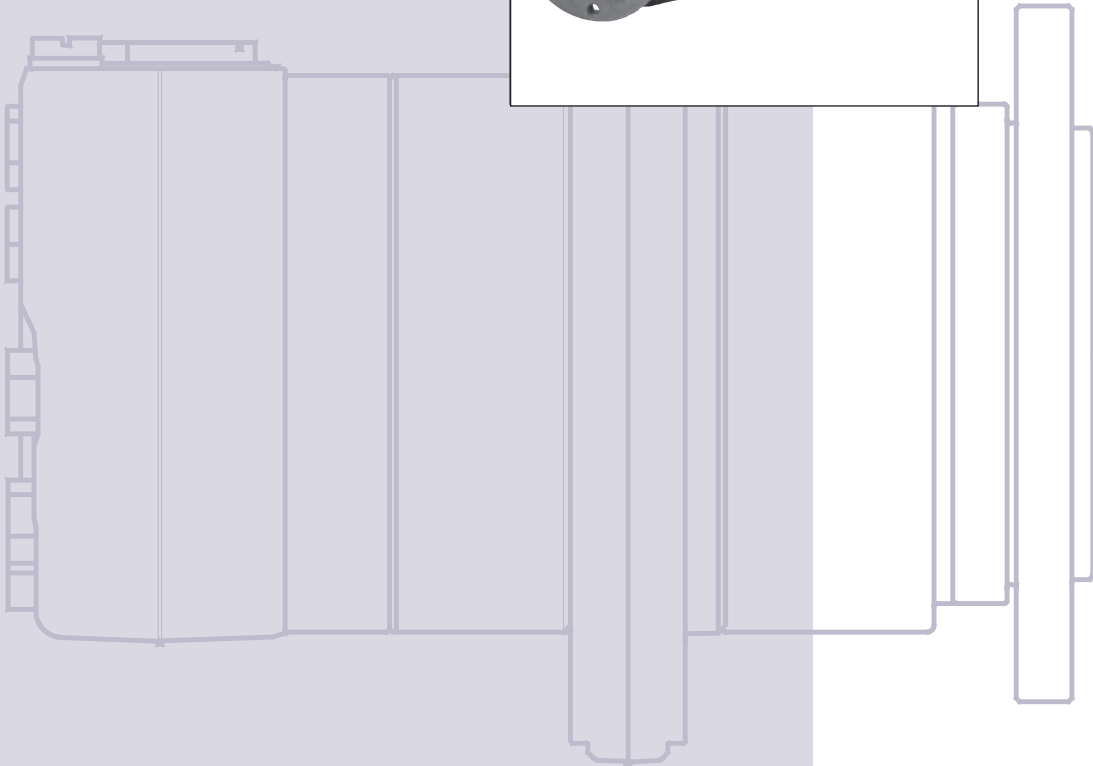
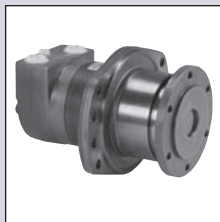
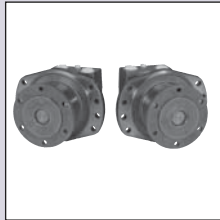
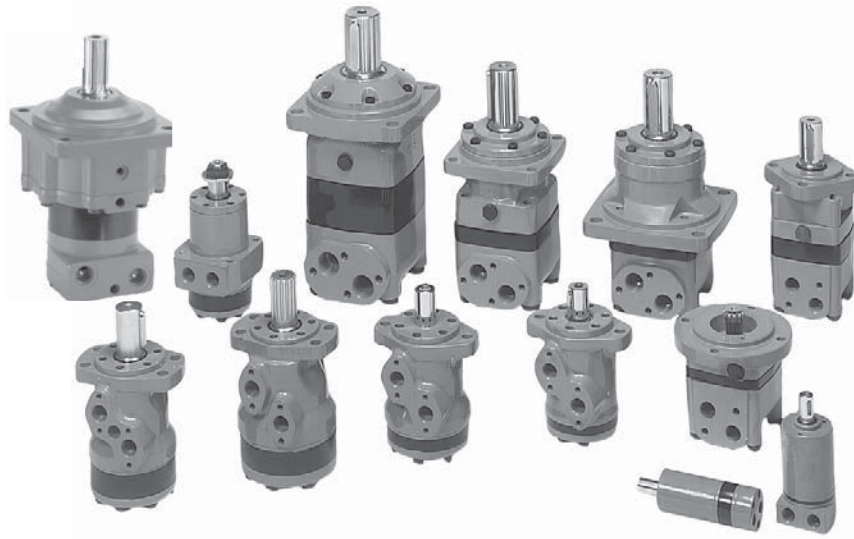

**A Wide Range of
Orbital Motors**

F300030 Tif

Sauer-Danfoss is a world leader within production of low speed orbital motors with high torque. We can offer more than 1600 different orbital motors, categorised in types, variants and sizes (incl. different shaft versions).

The motors vary in size (rated displacement) from 8 cm³ [0.50 in³] to 800 cm³ [48.9 in³] per revolution.

Speeds range up to approx. 2500 min⁻¹ (rpm) for the smallest type and up to approx. 600 min⁻¹ (rpm) for the largest type.

Maximum operating torques vary from 13 N•m [115 lbf•in] to 2700 N•m [24.000 lbf•in] (peak) and maximum outputs are from 2,0 kW [2,7 hp] to 70 kW [95 hp].

Characteristic features:

- Smooth running over the entire speed range
- Constant operating torque over a wide speed range
- High starting torque
- High return pressure without the use of drain line (High pressure shaft seal)
- High efficiency
- Long life under extreme operating conditions
- Robust and compact design
- High radial and axial bearing capacity
- For applications in both open and closed loop hydraulic systems
- Suitable for a wide variety of hydraulics fluids

The programme is characterised by technical features appealing to a large number

© 2010 Sauer-Danfoss. All rights reserved.

Sauer-Danfoss accepts no responsibility for possible errors in catalogs, brochures and other printed material. Sauer-Danfoss reserves the right to alter its products without prior notice. This also applies to products already ordered provided that such alterations can be made without affecting agreed specifications. All trademarks in this material are properties of their respective owners. Sauer-Danfoss, the Sauer-Danfoss logotype, the Sauer-Danfoss S-icon, PLUS+1™, What really matters is inside® and Know-How in Motion™ are trademarks of the Sauer-Danfoss Group.

Front page: F300 927, F300 928, F300 930, F300 932, F300 030, drawing:151Z21

**A Wide Range of
Orbital Motors
(continued)**

of applications and a part of the programme is characterised by motors that can be adapted to a given application. Adaptions comprise the following variants among others:

- Motors with corrosion resistant parts
- Wheel motors with recessed mounting flange
- OMP, OMR- motors with needle bearing
- OMR motor in low leakage version
- OMR motors in a super low leakage version
- Short motors without bearings
- Ultra short motors
- Motors with integrated positive holding brake
- Motors with integrated negative holding brake
- Motors with integrated flushing valve
- Motors with speed sensor
- Motors with tacho connection
- All motors are available with black finish paint

Planetary gears

Sauer-Danfoss complements the motor range with a complete programme of planetary gears adapted to suit. The combination of motors and gears makes it possible to obtain smooth running at fractional speeds and with torques up to 650 000 N·m [5 800 000 lbf·in].

The Sauer-Danfoss orbital motors are used in the following application areas:

- Construction equipment
- Agricultural equipment
- Material handling & Lifting equipment
- Forestry equipment
- Lawn and turf equipment
- Special purpose
- Machine tools and stationary equipment
- Marine equipment

**Survey of Literature with
Technical Data on
Sauer-Danfoss
Orbital Motors**

Detailed data on all Sauer-Danfoss motors can be found in our motor catalogue, which is divided into 6 individual subcatalogues:

- General information on Sauer-Danfoss orbital motors: function, use, selection of hydraulic motor, hydraulic systems, etc.
- Technical data on small motors: OML and OMM
- Technical data on medium sized motors: OMP, OMR, OMH and OMEW
- Technical data on medium sized motors: DH and DS
- Technical data on large motors: OMS, OMT and OMV
- Technical data on large motors: TMVW
- Technical data on large motors: TMT

A general survey brochure on Sauer-Danfoss orbital motors gives a quick motor reference based on power, torque, speed and capabilities.

Revision History

Table of Revisions

Date	Page	Changed	Rev
Oct 2004	All	Major update	B
Mar 2010	16	Japan location	BB

Contents

Speed and torque 5

Versions

Versions..... 6

Code Numbers

Code Numbers 7

Technical Data

Technical Data 8
 Max. Permissible shaft seal pressure, pressure drop in motor 9
 Oil flow in drain line, direction of shaft rotation 10
 Permissible shaft load 11
 Port thread versions 12

Dimensions

Dimensions..... 13

Weight

Weight of Motors..... 15

Speed and Torque

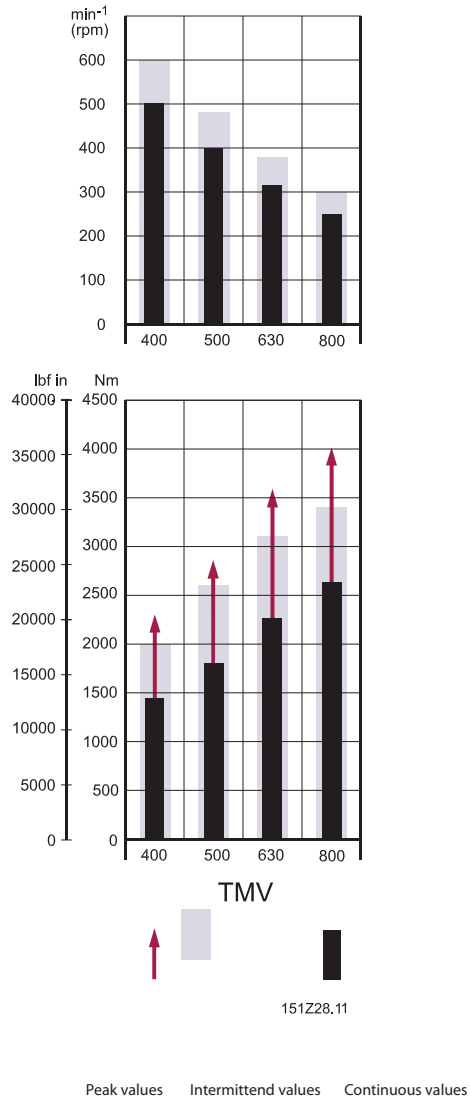

The bar diagrams above are useful for a quick selection of relevant motor size for the application.

Version

Mounting flange	Spigot diameter	Bolt circle diameter (BC)	Shaft	Port size	European version	US version	Side port version	End port version	Standard shaft seal	Drain connection	Check valve	Main type designation
Wheel	223.9 mm	265 mm	Thread hole flange	G 1	○		○		○	○	No	TMVW
	223.9 mm	265 mm	Thread hole flange	1 5/16 - 12 UN		○	○		○	○	No	TMVW

→
→
→

Motors are painted black

Code Numbers

	Code numbers	Displacement (cm ³)				Technical data - page	Dimensions - page
		400	500	630	800		
→							
→							
→	151Z	8205	8206	8207	8208	8	13
	151Z	8210	8211	8212	8213	8	14

Ordering

Add the four digit prefix "151Z" to the four digit numbers from the chart for complete code number.

Example:

151Z8207 for an TMVW 630 with mounting flange \varnothing 223.9 mm, port size G 1 and side port version.

Orders will not be accepted without the four digit prefix.

Technical Data for TMVW

Type			TMVW	TMVW	TMVW	TMVW
Motor size			400	500	630	800
Geometric displacement	cm ³ [in ³]		400.9 [24.46]	499.6 [30.49]	629.1 [38.39]	801.8 [48.93]
Max. Speed	min ⁻¹ [rpm]	cont.	500	400	315	250
		int. ¹⁾	600	480	380	300
Max. Torque	N.m [lbf.in]	cont.	1440 [12745]	1800 [15930]	2270 [20090]	2590 [22880]
		int. ¹⁾	2000 [17700]	2600 [23010]	3100 [27440]	3400 [30090]
		peak ²⁾	2300 [20355]	2860 [25315]	3600 [31860]	4020 [35580]
Max. Output	kW [hp]	cont.	67 [90]	67 [90]	67 [90]	67 [90]
		int. ¹⁾	112 [150]	112 [150]	112 [150]	112 [150]
Max. pressure drop	bar [psi]	cont.	250 [3630]	250 [3630]	250 [3630]	225 [3263]
		int. ¹⁾	350 [5080]	350 [5080]	350 [5080]	300 [4350]
		peak ²⁾	400 [5800]	400 [5800]	400 [5800]	400 [5800]
Max. oil flow	l/min [US gal/min]	cont.	200 [63.4]	200 [63.4]	200 [63.4]	200 [63.4]
		int. ¹⁾	240 [63.4]	240 [63.4]	240 [63.4]	240 [63.4]
Max. starting pressure with unloaded shaft	bar [psi]		5 [70]	5 [70]	5 [70]	5 [70]
Min. starting torque		at max. press. drop cont.: N•m [lbf•in]	1245 [11020]	1551 [13730]	1953 [17290]	2490 [22035]
		at max. press. drop int. ¹⁾ : N•m [lbf•in]	1743 [15425]	2172 [19220]	2735 [24205]	2988 [26440]

Type			Max. inlet pressure	Max. return pressure
TMVW 400 - 800	bar [psi]	cont.	270 [3915]	140 [2030]
	bar [psi]	int. ¹⁾	370 [5365]	175 [2540]
	bar [psi]	peak ²⁾	420 [6090]	210 [3045]

¹⁾ Intermittend operation: the permissible values may occur for max. 10% of every minute

²⁾ Peak load: the permissible value may occur for max. 1% of every minute

Max. Permissible Shaft Seal Pressure

TMVW with standard shaft seal and drain connection
The pressure on shaft seal equals the pressure in the drain line.

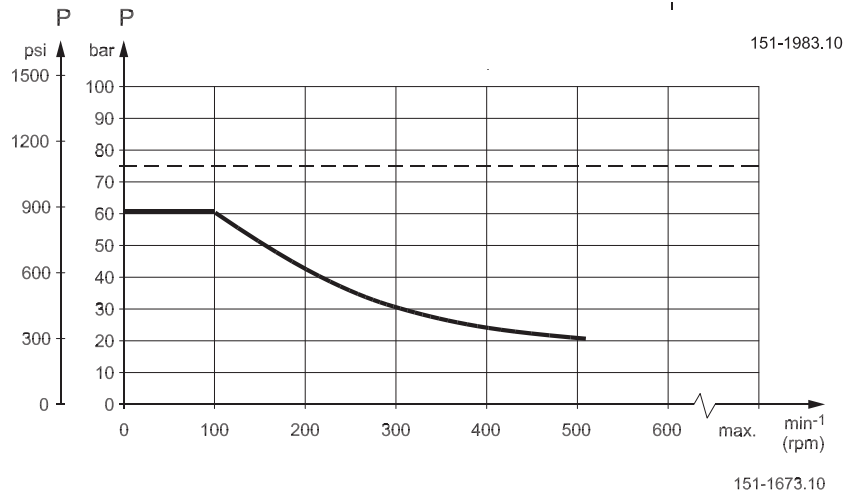
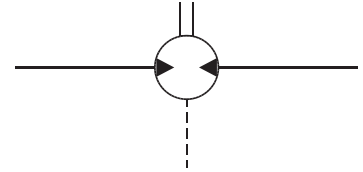

---- Intermittent operation: The permissible values may occur for max. 10% of every minute.
— Continuous operation

Warning
Drain line should always be used.

Pressure Drop in Motor

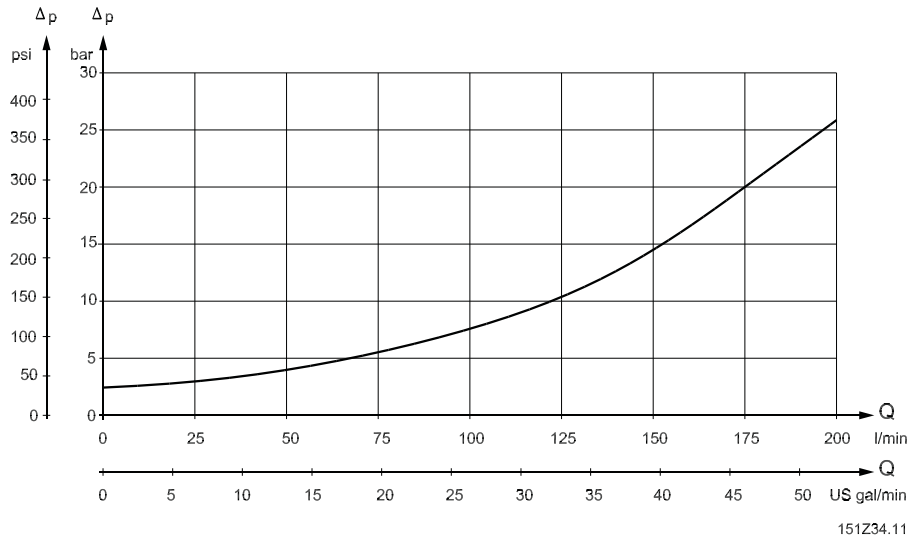

The curve applies to an unloaded motor shaft and an oil viscosity of 35 mm²/s [165 SUS].

Oil Flow in Drain Line

The table below shows the max. oil flow in the drain line at a return pressure less than 5-10 bar [75-150 psi].

Pressure drop bar [psi]	Viscosity mm ² /s [SUS]	Oil flow in drain line l/min [US gal/min]
200 [2900]	20 [100]	2.5 [0.66]
	35 [165]	1.5 [0.4]
275 [3990]	20 [100]	4.0 [1.1]
	35 [165]	2.5 [0.66]

**Direction of Shaft
 Rotation**

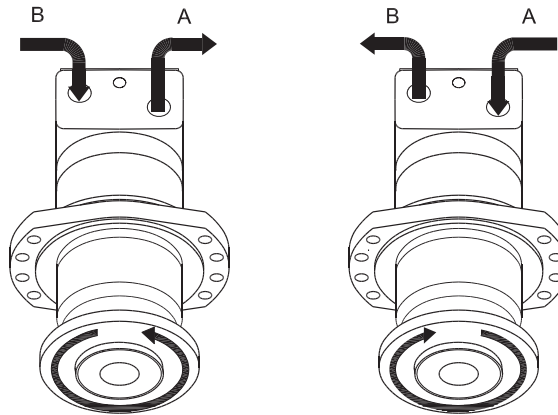

151Z31.10

**Permissible Shaft Load
 for TMVW**

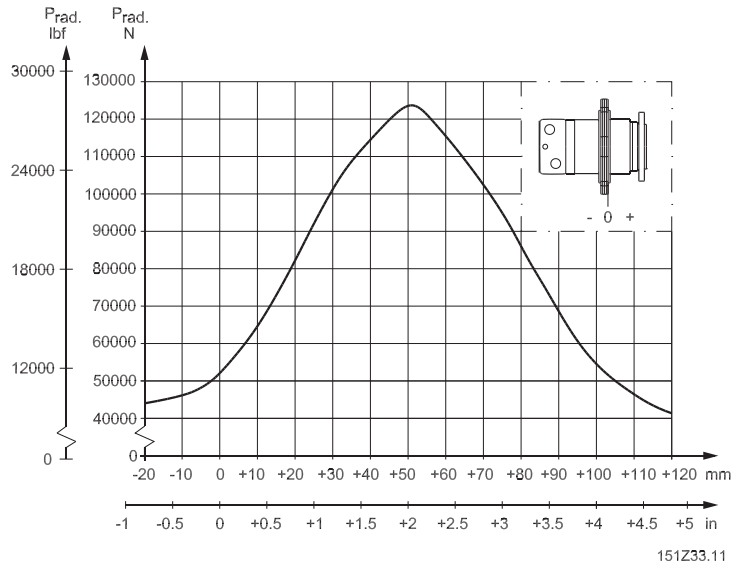

Permissible radial shaft load

The output shaft runs in tapered roller bearings that permit high axial and radial forces.

The permissible radial load on the shaft is shown for an axial load of 0 N as a function of the distance from the mounting flange to the point of load application.

The curve is based on B_{10} Bearing life (2000 hours or 12 000 000 shaft revolutions at 100 min^{-1}) at rated output torque, when mineral-based hydraulic oil with a sufficient content of anti-wear additives, is used.

Port Thread Versions

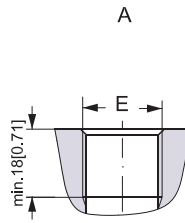

A: G Main port
E: ISO 228/1 – G 1

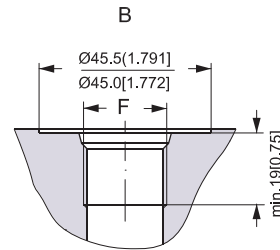

B: UNF Main port
F: 1 ⁵/₁₆ – 12 UN
O-ring boss port

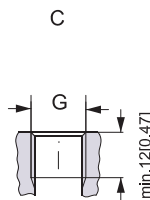

C: G Drain port
G: ISO 228/1 – G 1/4

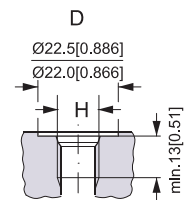

D: UNF Drain port
H: ⁹/₁₆ – 18 UN
O-ring boss port

151-1978.10

Dimensions

Wheel flange-spigot diameter $\varnothing 223.9$ mm - BC $\varnothing 265$ mm

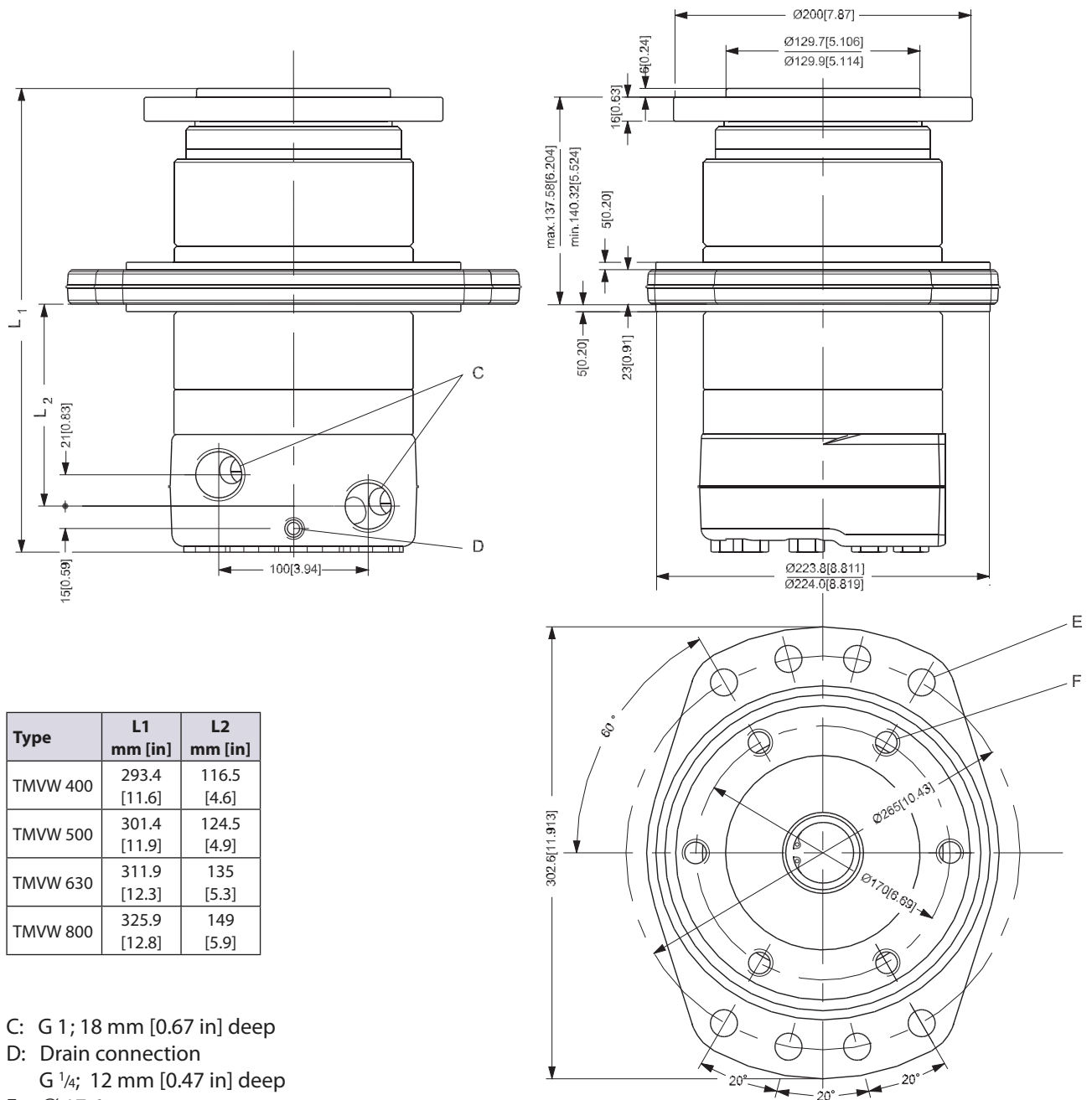

Type	L1 mm [in]	L2 mm [in]
TMVW 400	293.4 [11.6]	116.5 [4.6]
TMVW 500	301.4 [11.9]	124.5 [4.9]
TMVW 630	311.9 [12.3]	135 [5.3]
TMVW 800	325.9 [12.8]	149 [5.9]

- C: G 1; 18 mm [0.67 in] deep
- D: Drain connection
 G 1/4; 12 mm [0.47 in] deep
- E: $\varnothing 17.6$
- F: 6 • M16 • 1.5

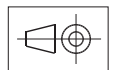

151Z09.12

Dimensions

Wheel flange-spigot diameter $\varnothing 223.9$ mm - BC $\varnothing 265$ mm

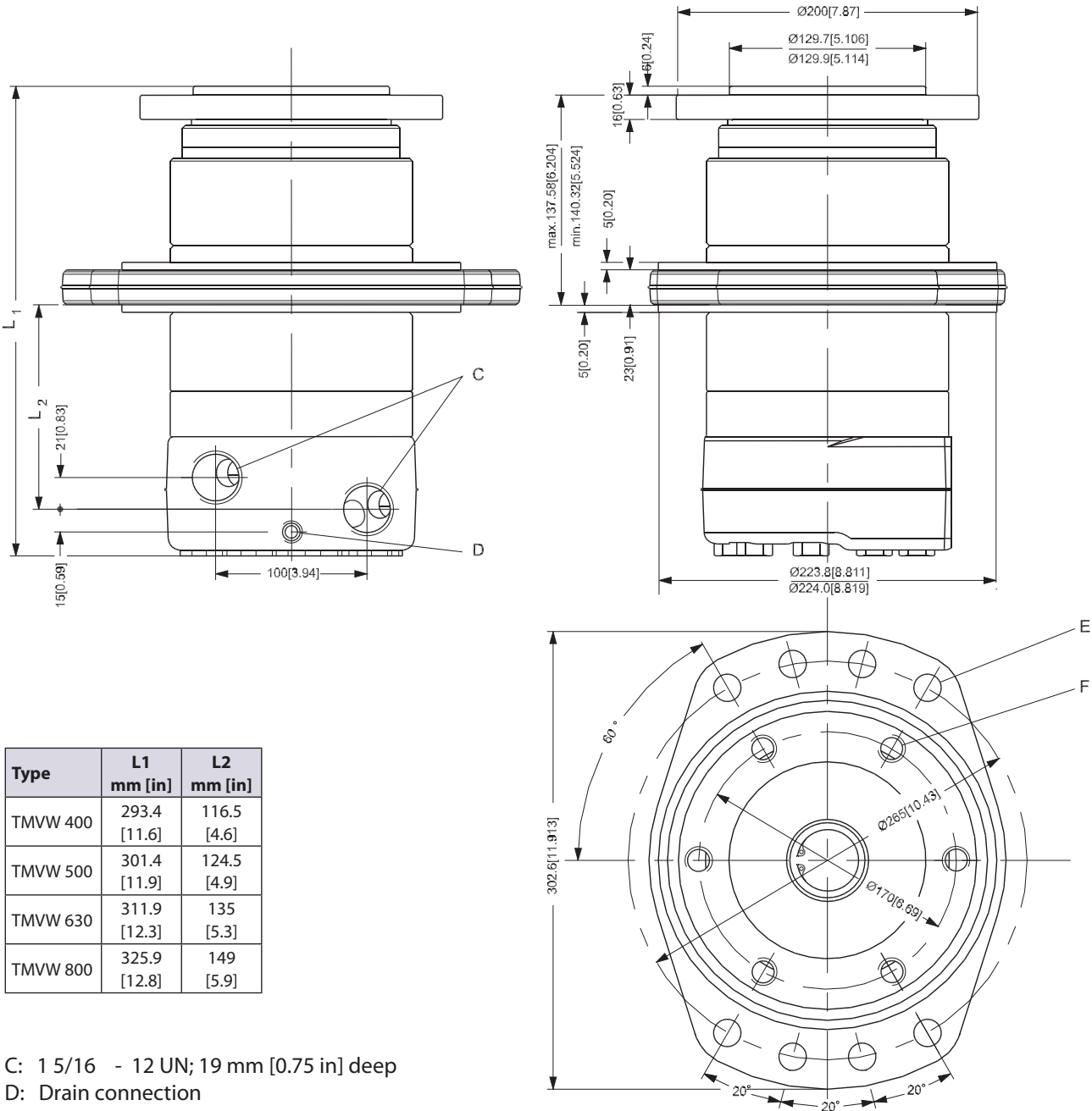

Type	L1 mm [in]	L2 mm [in]
TMVW 400	293.4 [11.6]	116.5 [4.6]
TMVW 500	301.4 [11.9]	124.5 [4.9]
TMVW 630	311.9 [12.3]	135 [5.3]
TMVW 800	325.9 [12.8]	149 [5.9]

- C: 1 5/16 - 12 UN; 19 mm [0.75 in] deep
- D: Drain connection
 9/16 - 18 UNF; 13 mm [0.51 in] deep
- E: $\varnothing 17.6$
- F: 6 • M16 • 1.5

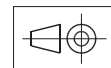

151Z09.12

Weight of Motors

Code no	Weight	
	kg	[lb]
151Z8205	43.5	[95.90]
151Z8206	44.4	[97.89]
151Z8207	45.8	[100.97]
151Z8208	47.4	[104.50]
151Z8210	43.5	[95.90]
151Z8211	44.4	[97.89]
151Z8212	45.8	[100.97]
151Z8213	47.4	[104.50]

Our Products

Open circuit axial piston pumps
 Gear pumps and motors
 Fan drive systems
 Closed circuit axial piston pumps and motors
 Bent axis motors
 Hydrostatic transmissions
 Transit mixer drives
 Hydrostatic transaxles
 Electrohydraulics
 Integrated systems
 Microcontrollers and software
 PLUS+1™ GUIDE
 Displays
 Joysticks and control handles
 Sensors
 Orbital motors
 Inverters
 Electrohydraulic power steering
 Hydraulic power steering
 Hydraulic integrated circuits (HIC)
 Cartridge valves
 Directional spool valves
 Proportional valves

Sauer-Danfoss Mobile Power and Control Systems – Market Leaders Worldwide

Sauer-Danfoss is a comprehensive supplier providing complete systems to the global mobile market.

Sauer-Danfoss serves markets such as agriculture, construction, road building, material handling, municipal, forestry, turf care, and many others.

We offer our customers optimum solutions for their needs and develop new products and systems in close cooperation and partnership with them.

Sauer-Danfoss specializes in integrating a full range of system components to provide vehicle designers with the most advanced total system design.

Sauer-Danfoss provides comprehensive worldwide service for its products through an extensive network of Global Service Partners strategically located in all parts of the world.

Local address:

Sauer-Danfoss (US) Company
 2800 East 13th Street
 Ames, IA 50010, USA
 Phone: +1 515 239-6000
 Fax: +1 515 239 6618

Sauer-Danfoss ApS
 DK-6430 Nordborg, Denmark
 Phone: +45 7488 4444
 Fax: +45 7488 4400

Sauer-Danfoss GmbH & Co. OHG
 Postfach 2460, D-24531 Neumünster
 Krokamp 35, D-24539 Neumünster, Germany
 Phone: +49 4321 871-0
 Fax: +49 4321 871 122

Sauer-Danfoss-Daikin LTD.
 Shin-Osaka TERASAKI 3rd Bldg. 6F
 1-5-28 Nishimiyahara, Yodogawa-ku
 Osaka 532-0004, Japan
 Phone: +81 6 6395 6066
 Fax: +81 6 6395 8585